

PROPRIETARY TO ELO TOUCH SOLUTIONS, INC. AND SHALL NOT BE DISCLOSED OTHER THAN TO NECESSARY EMPLOYEES OR SUPPLIERS WITHOUT THE EXPRESS WRITTEN CONSENT OF ELO TOUCH SOLUTIONS INC.

REVISIONS					
REV	ZONE	BY	DESCRIPTION	DATE	APPROVED
G	--	-	-	02/10/10	
H		BA	ECO-12-014540: REBRANDED TO ELO TOUCH SOLUTIONS	08/31/12	DD

- NOTES:
 1. ALL DIMENSIONS +/- 1.0MM UNLESS NOTED
 2. DIMENSIONS SHOW ARE FOR ALL TOUCH TECHNOLOGIES UNLESS NOTED

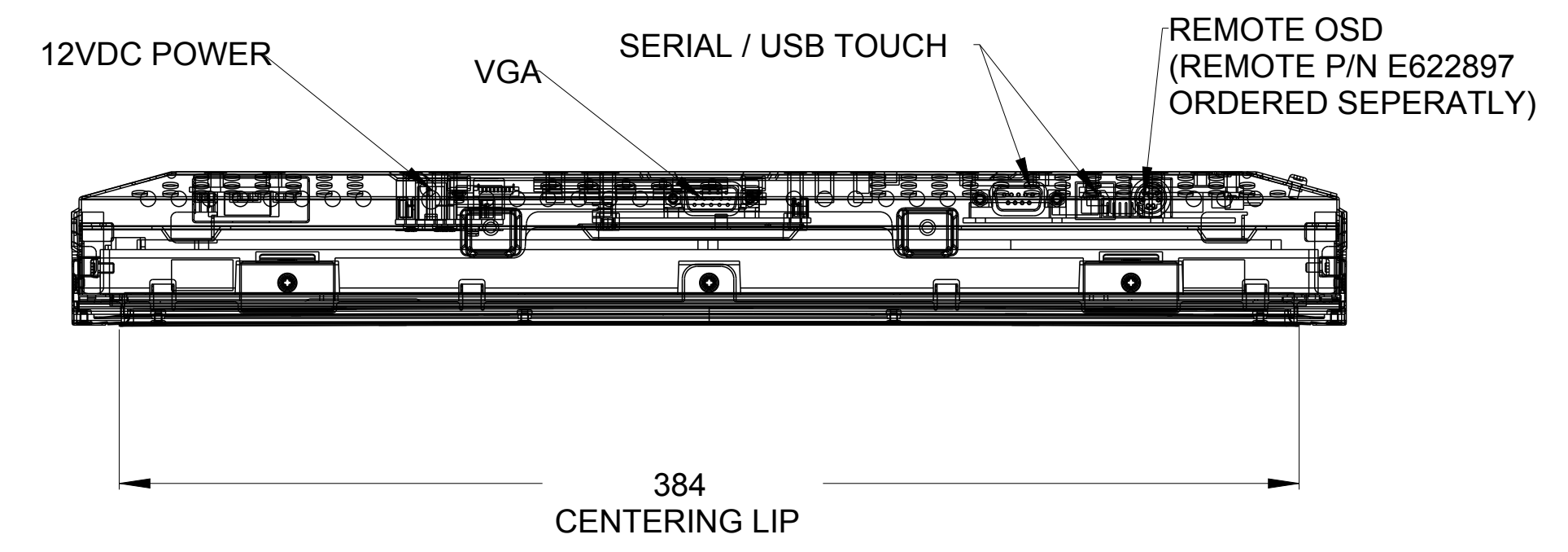
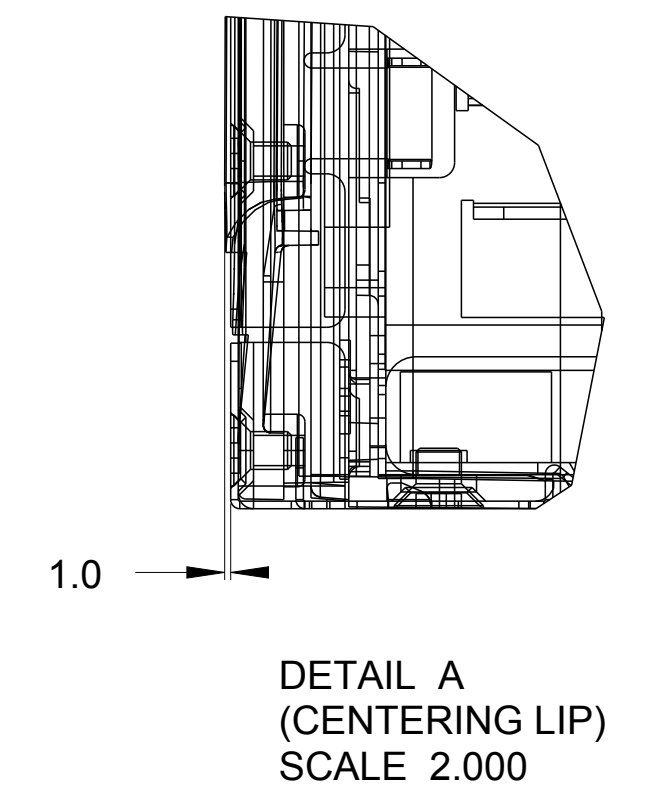
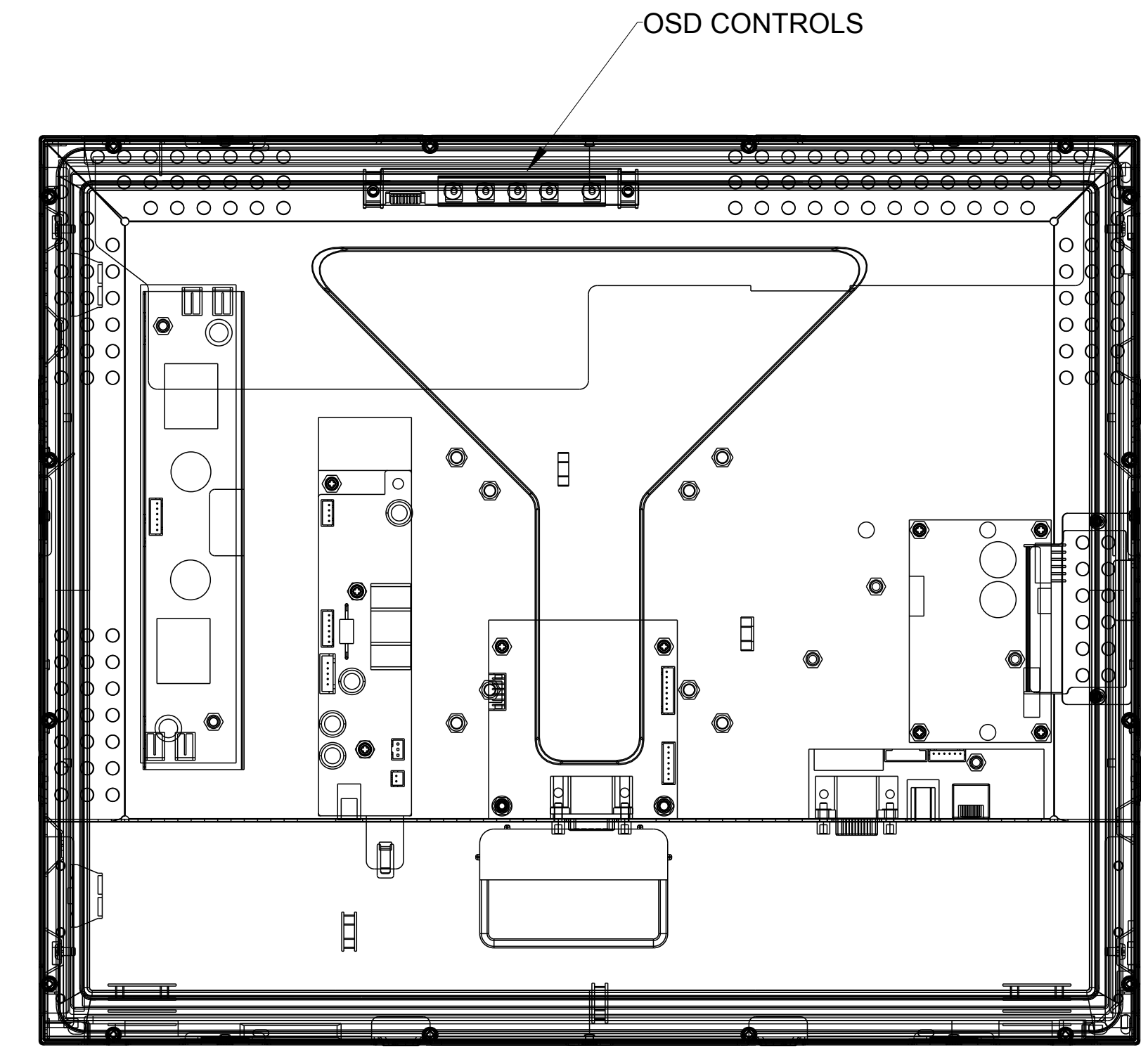
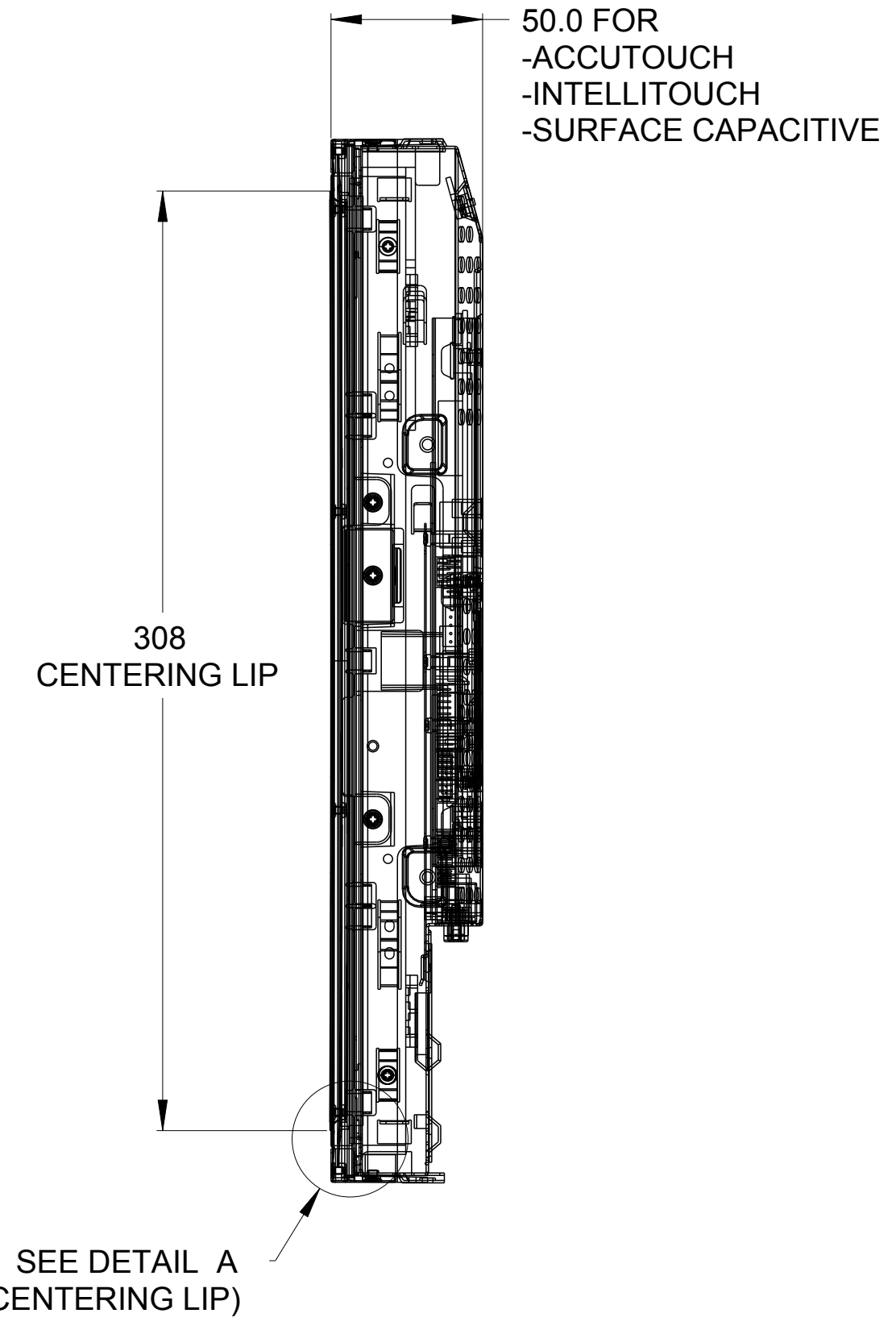
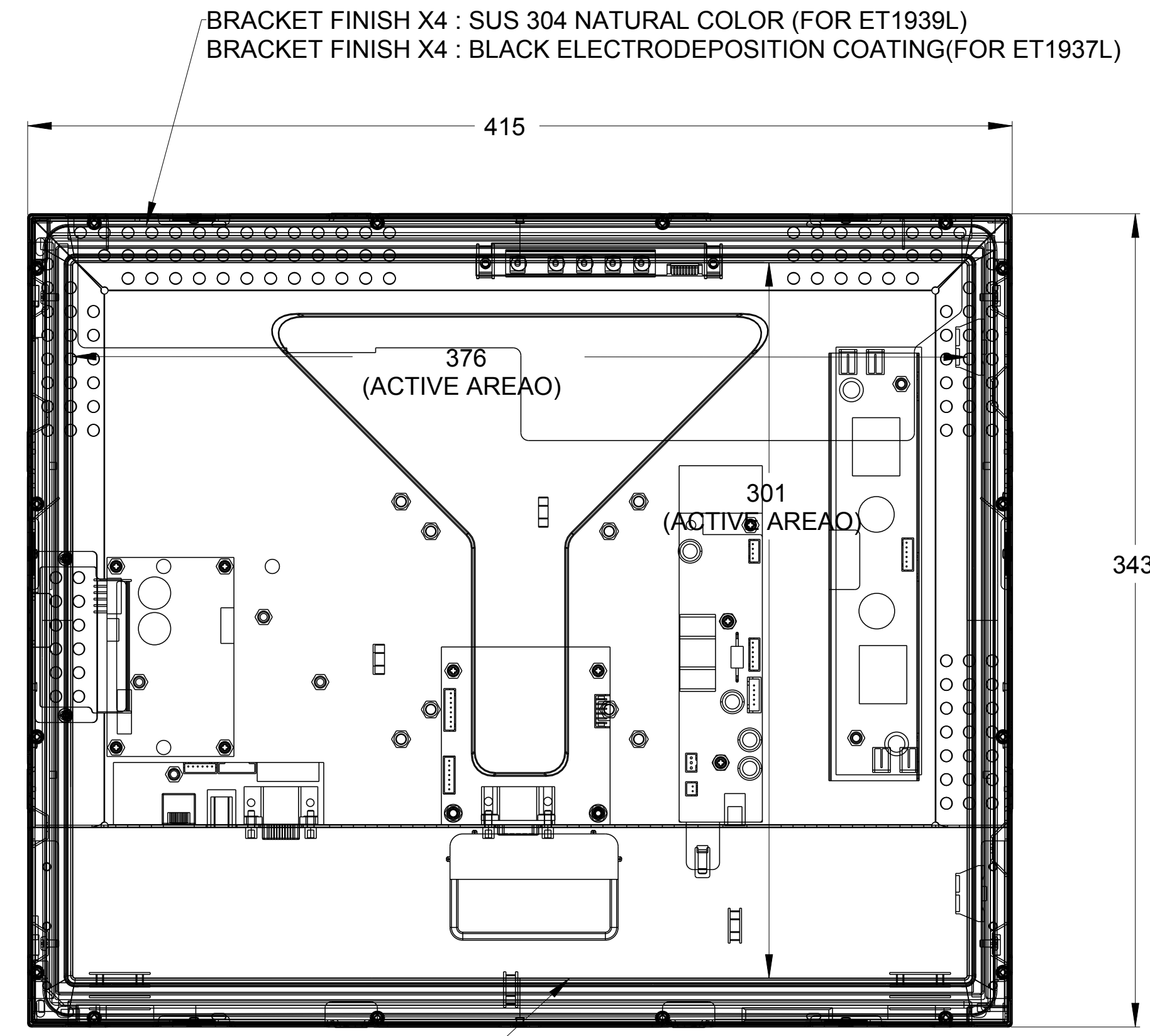

ITEM NO.	QTY REQ'D	DRAWING OR PART NO.	DESCRIPTION	MATERIAL SPECIFICATION
PARTS LIST				
PART. NO.		UNLESS OTHERWISE SPECIFIED ALL DIMENSIONS ARE IN MILLIMETERS	DRAWN -	DATE -
METRIC		TOLERANCES ARE: DECIMALS ±1/ 2" ANGLES ±1/ 32" FRACTIONS ±1/ 32"	CHECK -	DATE -
			DESIGN -	DATE -
DO NOT SCALE DRAWING		THIRD ANGLE PROJECTION		TITLE DIMENSIONAL DRAWING ET1939L/ ET1937L-XCWA-X
ProjE prt/asm: MS500786_E_ET1939L_APR_RCK.PRT ProjE drw: MS500786_REVH.DRW				

H REV
 1 OF 8 SHIT
 MS500786 DWG. NO.

PROPRIETARY TO ELO TOUCH SOLUTIONS, INC. AND SHALL NOT BE DISCLOSED OTHER THAN TO NECESSARY EMPLOYEES OR SUPPLIERS WITHOUT THE EXPRESS WRITTEN CONSENT OF ELO TOUCH SOLUTIONS INC.

REVISIONS					
REV	ZONE	BY	DESCRIPTION	DATE	APPROVED
H	--	BA	SEE SHEET 1	08/31/12	DD

SECURE TOUCH OPTION (FOR ET1939L ONLY)

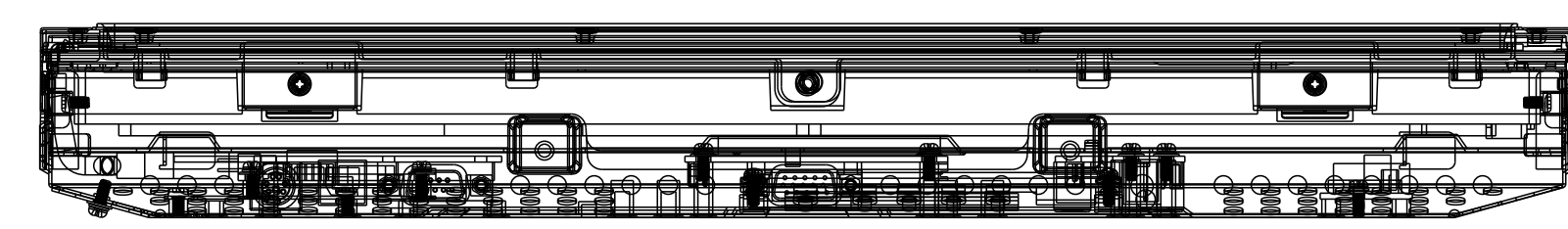
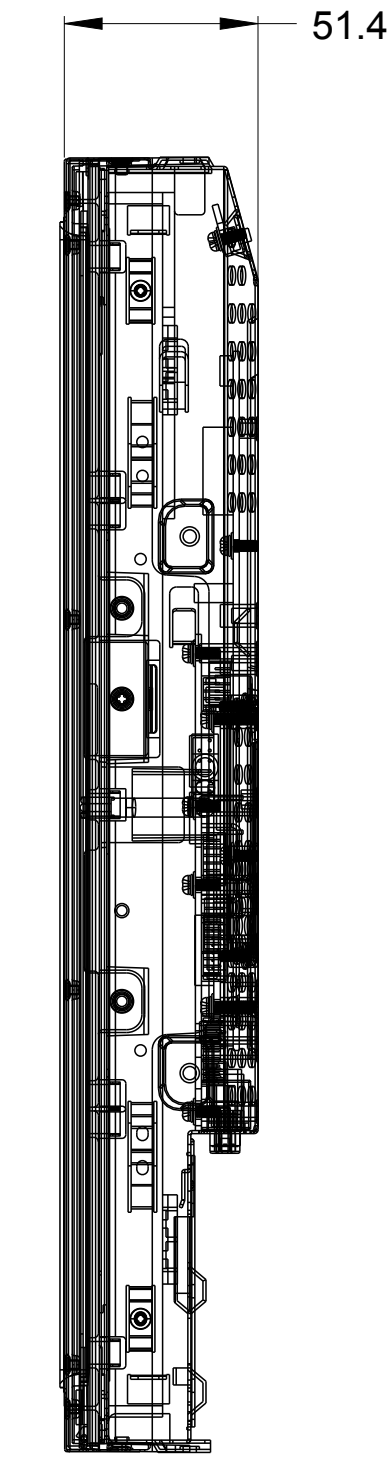
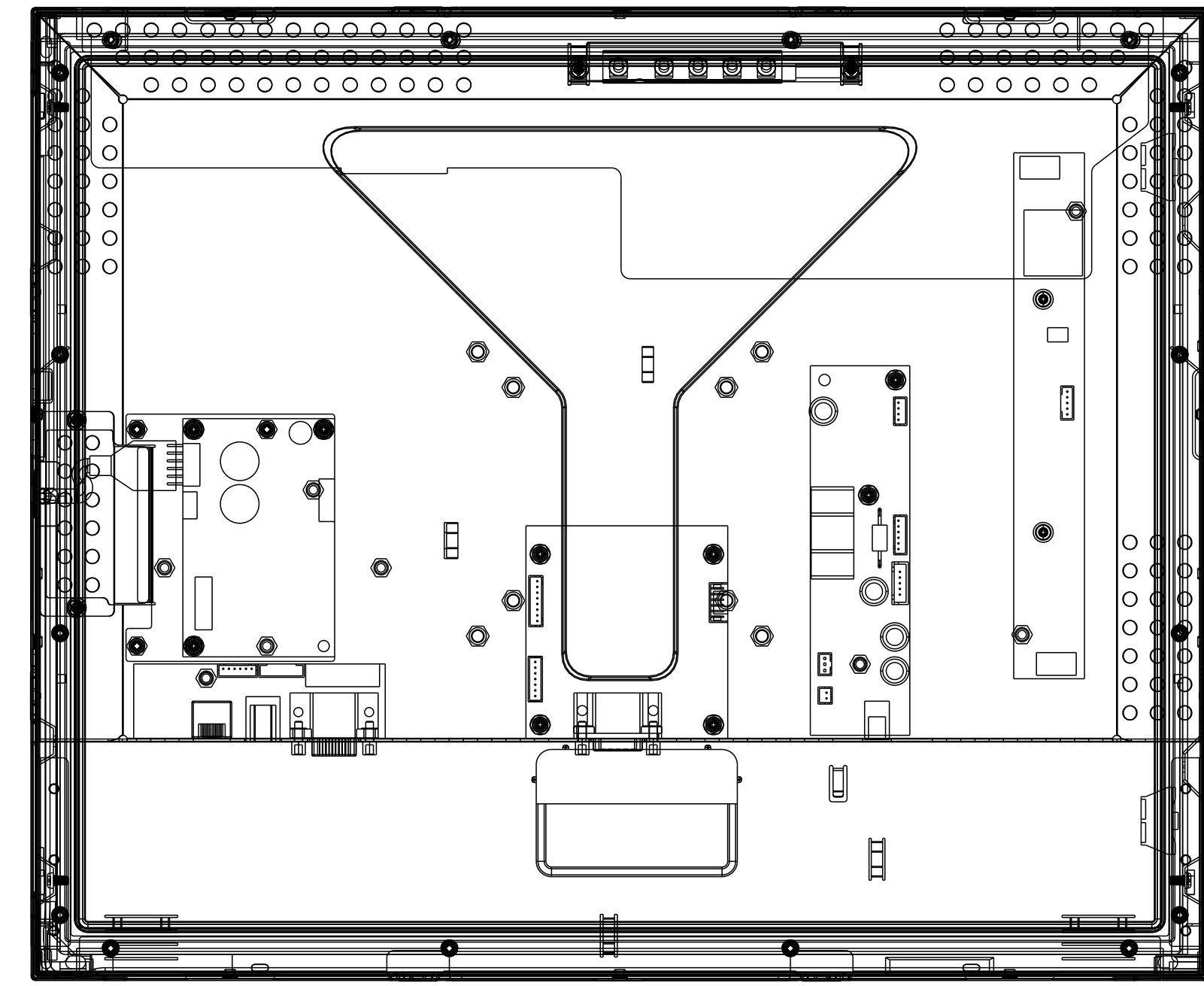

ITEM NO.	QTY REQ'D	DRAWING OR PART NO.	DESCRIPTION	MATERIAL SPECIFICATION
PARTS LIST				
PART. NO.		UNLESS OTHERWISE SPECIFIED ALL DIMENSIONS ARE IN MILLIMETERS		DRAWN -
METRIC		TOLERANCES ARE:		DATE -
DO NOT SCALE DRAWING		DECIMALS	ANGLES	CHECK
Pro/E prt/asm: MS500786_E_ET1939L_APR.PRT		X ± 0.50	± 1/ 2°	DATE
Pro/E drw: MS500786_REVH.DRW		X ± 0.25	FRACTIONS	DESIGN
		XX ± 0.13	± 1/ 32	DATE
				THIRD ANGLE PROJECTION
				TITLE
				DIMENSIONAL DRAWING
				ET1939L/
				ET1937L-XCWA-X
		SIZE	SCALE	SHEET
		D	0.333	2 OF 8
		DWG. NO.	REV	
		MS500786	H	

H REV
 C SH1 OF 8
 B MS500786
 A DWG. NO.

PROPRIETARY TO ELO TOUCHSOLUTIONS, INC. AND SHALL NOT BE DISCLOSED OTHER THAN TO NECESSARY EMPLOYEES OR SUPPLIERS WITHOUT THE EXPRESS WRITTEN CONSENT OF ELO TOUCH SOLUTIONS INC.

REVISIONS					
REV	ZONE	BY	DESCRIPTION	DATE	APPROVED
H	--	BA	SEE SHEET 1	08/31/12	DD

IR OPTION (FOR ET1939L ONLY)

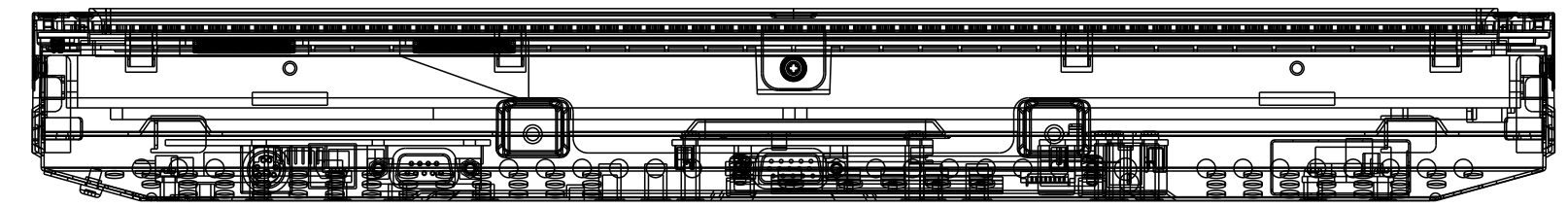
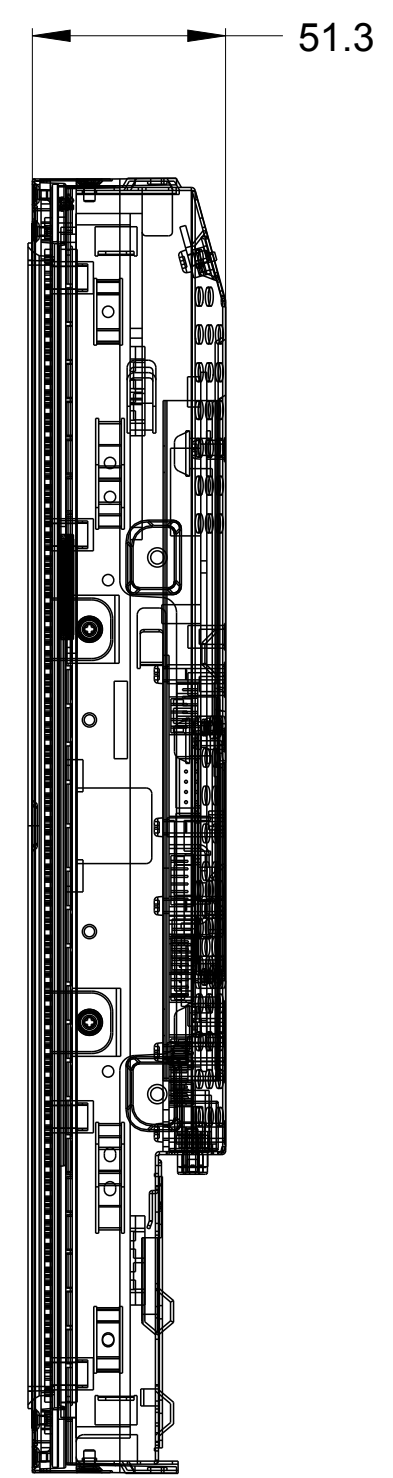
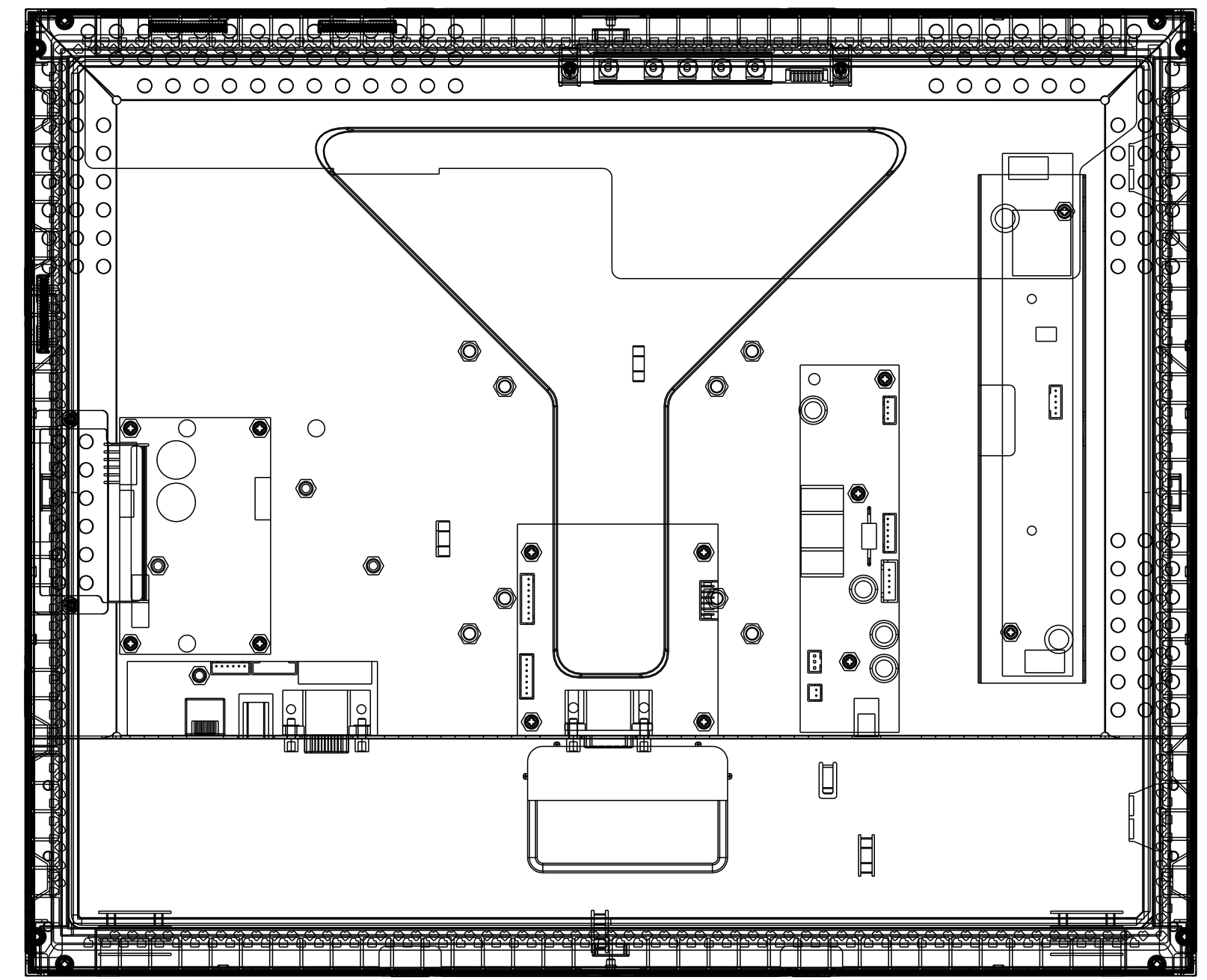

ITEM NO.	QTY REQ'D	DRAWING OR PART NO.	DESCRIPTION	MATERIAL SPECIFICATION
PARTS LIST				
PART. NO.		UNLESS OTHERWISE SPECIFIED ALL DIMENSIONS ARE IN MILLIMETERS	DRAWN -	DATE -
METRIC		TOLERANCES ARE: DECIMALS ANGLES X ± 0.50 ±1/ 2° X ± 0.25 FRACTIONS XX ± 0.13 ±1/ 32	CHECK	DATE
			DESIGN	DATE
DO NOT SCALE DRAWING			THIRD ANGLE PROJECTION	
Pro/E prt/asm: MS500786_E_ET1939L_APR_RCK.PRT				SIZE D
Pro/E drw: MS500786_REVH.DRW		SCALE 0.333	SHEET 3 OF 8	DWG. NO. MS500786
				REV H

REV H
SHT 3 OF 8
DWG. NO. MS500786

D
C
B
A

8

7

6

5

4

3

2

1

8

7

6

5

4

3

2

1

PROPRIETARY TO ELO TOUCH SOLUTIONS, INC. AND SHALL NOT BE DISCLOSED OTHER THAN TO NECESSARY EMPLOYEES OR SUPPLIERS WITHOUT THE EXPRESS WRITTEN CONSENT OF ELO TOUCH SOLUTIONS INC.

REVISIONS					
REV	ZONE	BY	DESCRIPTION	DATE	APPROVED
H	--	BA	SEE SHEET 1	08/31/12	DD

APR OPTION

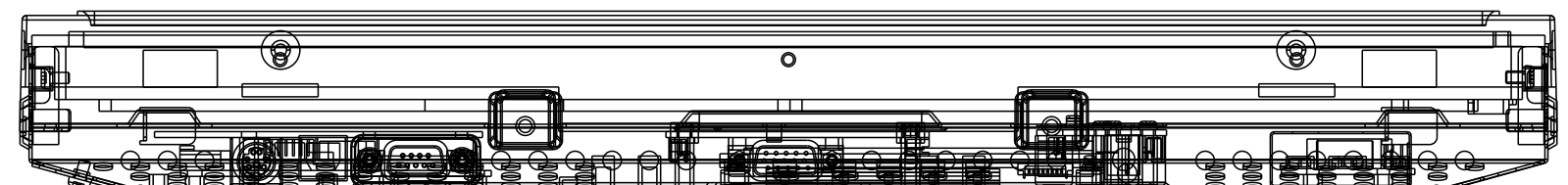
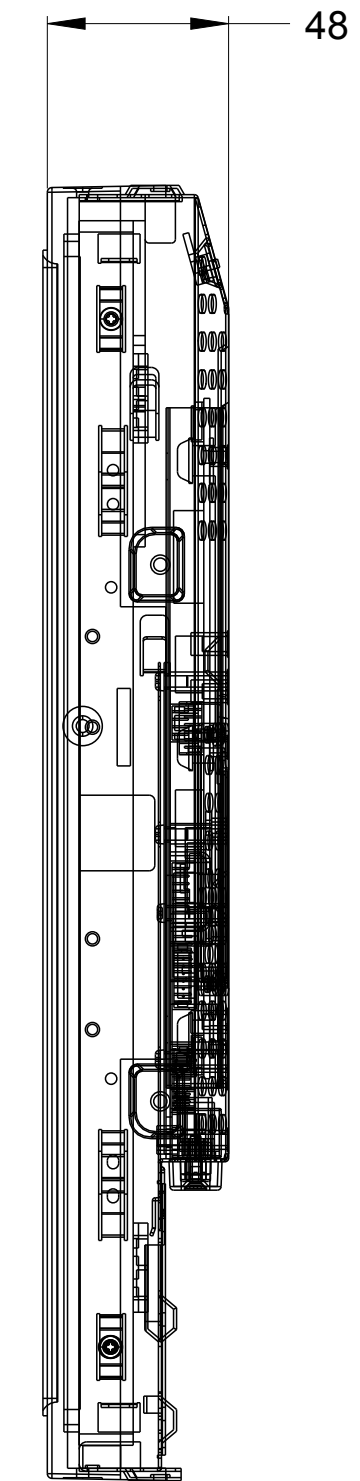
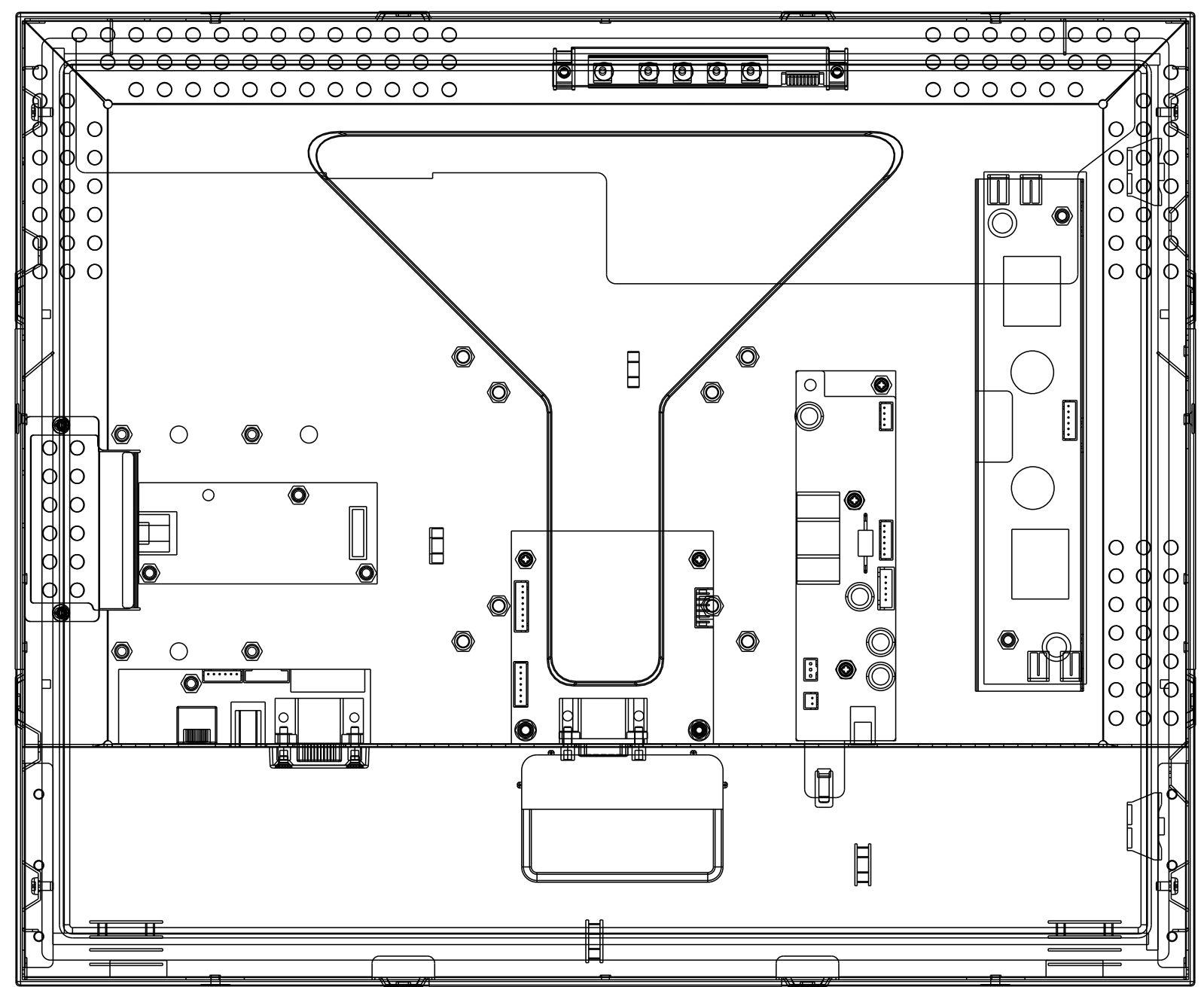

ITEM NO.	QTY REQ'D	DRAWING OR PART NO.	DESCRIPTION	MATERIAL SPECIFICATION
PARTS LIST				
PART. NO.		UNLESS OTHERWISE SPECIFIED ALL DIMENSIONS ARE IN MILLIMETERS	DRAWN -	DATE -
METRIC		TOLERANCES ARE: DECIMALS ANGLES X ± 0.50 ± 1/ 2° X ± 0.25 FRACTIONS XX ± 0.13 ± 1/ 32	CHECK	DATE
			DESIGN	DATE
DO NOT SCALE DRAWING		THIRD ANGLE PROJECTION		TITLE
Pro/E prt/asm: MS500786_E_ET1939L_APR.PRT				DIMENSIONAL DRAWING ET1939L/ ET1937L-XCWA-X
Pro/E drw: MS500786_REVH.DRW				
SIZE	SCALE	SHEET	DWG. NO.	REV
D	0.500	4 OF 8	MS500786	H

REV H
SHT 4 OF 8
DWG. NO. MS500786

PROPRIETARY TO ELO TOUCH SOLUTIONS, INC. AND SHALL NOT BE DISCLOSED OTHER THAN TO NECESSARY EMPLOYEES OR SUPPLIERS WITHOUT THE EXPRESS WRITTEN CONSENT OF ELO TOUCH SOLUTIONS INC.

REVISIONS					
REV	ZONE	BY	DESCRIPTION	DATE	APPROVED
H	--	BA	SEE SHEET 1	08/31/12	DD

LVDS OPTION (FOR ET1939L ONLY)

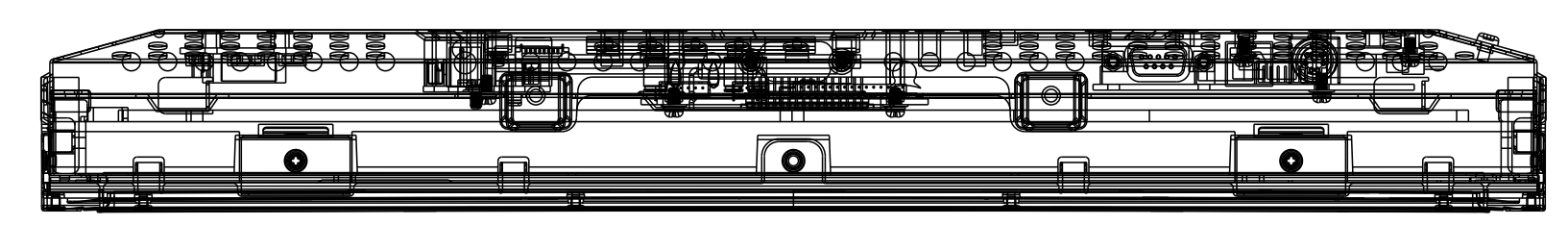
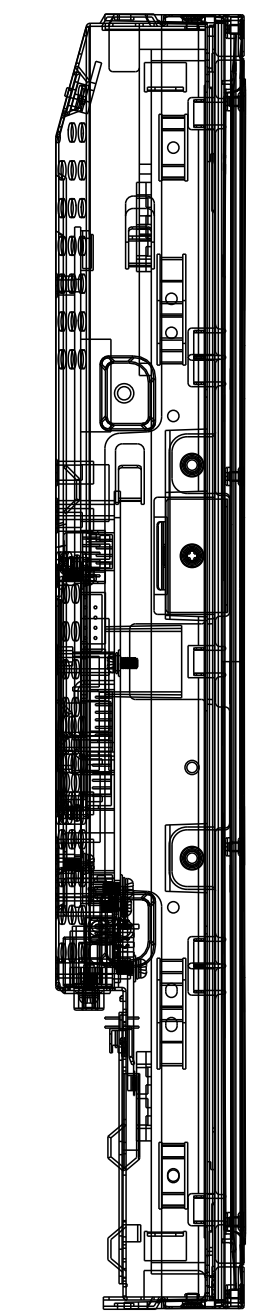
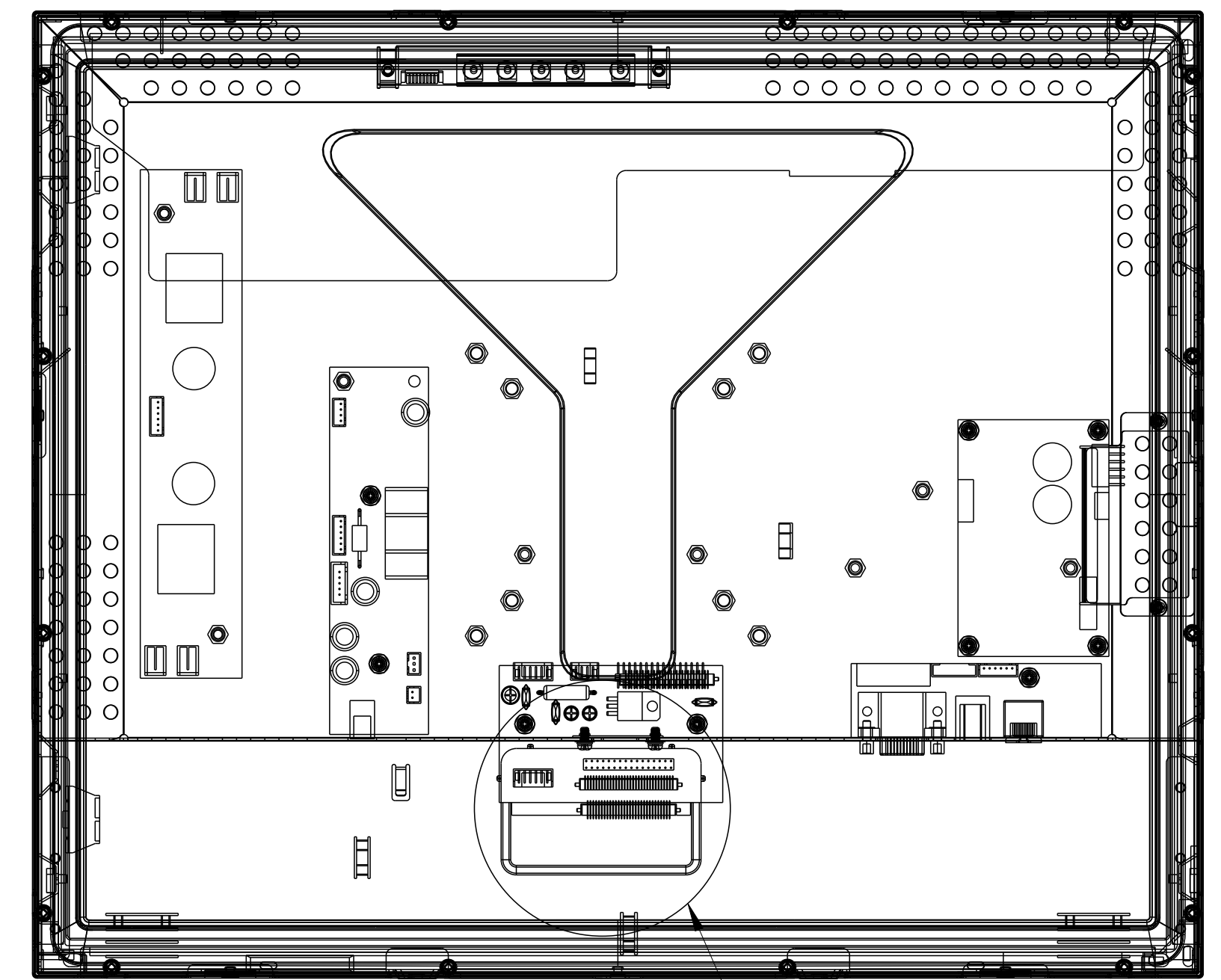

SEE USER GUIDE FOR LVDS CONNECTION DETAILS

ITEM NO.	QTY REQ'D	DRAWING OR PART NO.	DESCRIPTION	MATERIAL SPECIFICATION
PARTS LIST				
PART. NO.		UNLESS OTHERWISE SPECIFIED ALL DIMENSIONS ARE IN MILLIMETERS	DRAWN -	DATE -
METRIC		TOLERANCES ARE: DECIMALS ANGLES X ± 0.50 ± 1/ 2° X ± 0.25 FRACTIONS XX ± 0.13 ± 1/ 32	CHECK	DATE
			DESIGN	DATE
DO NOT SCALE DRAWING		THIRD ANGLE PROJECTION		TITLE
				DIMENSIONAL DRAWING
				ET1939L/
				ET1937L-XCWA-X
Pro/E prt/asm: MS500786_E_ET1939L_APR.PRT				
Pro/E drw: MS500786_REVH.DRW		SIZE	SCALE	
		D	0.333	5 OF 8
		DWG. NO.	REV	
		MS500786	H	

DWG. NO. MS500786

PROPRIETARY TO ELO TOUCH SOLUTIONS, INC. AND SHALL NOT BE DISCLOSED OTHER THAN TO NECESSARY EMPLOYEES OR SUPPLIERS WITHOUT THE EXPRESS WRITTEN CONSENT OF ELO TOUCH SOLUTIONS INC.

REVISIONS					
REV	ZONE	BY	DESCRIPTION	DATE	APPROVED
H	--	BA	SEE SHEET 1	08/31/12	DD

RECOMMENDED CUSTOMER PANEL CUT-OUT (SEE NOTE A)

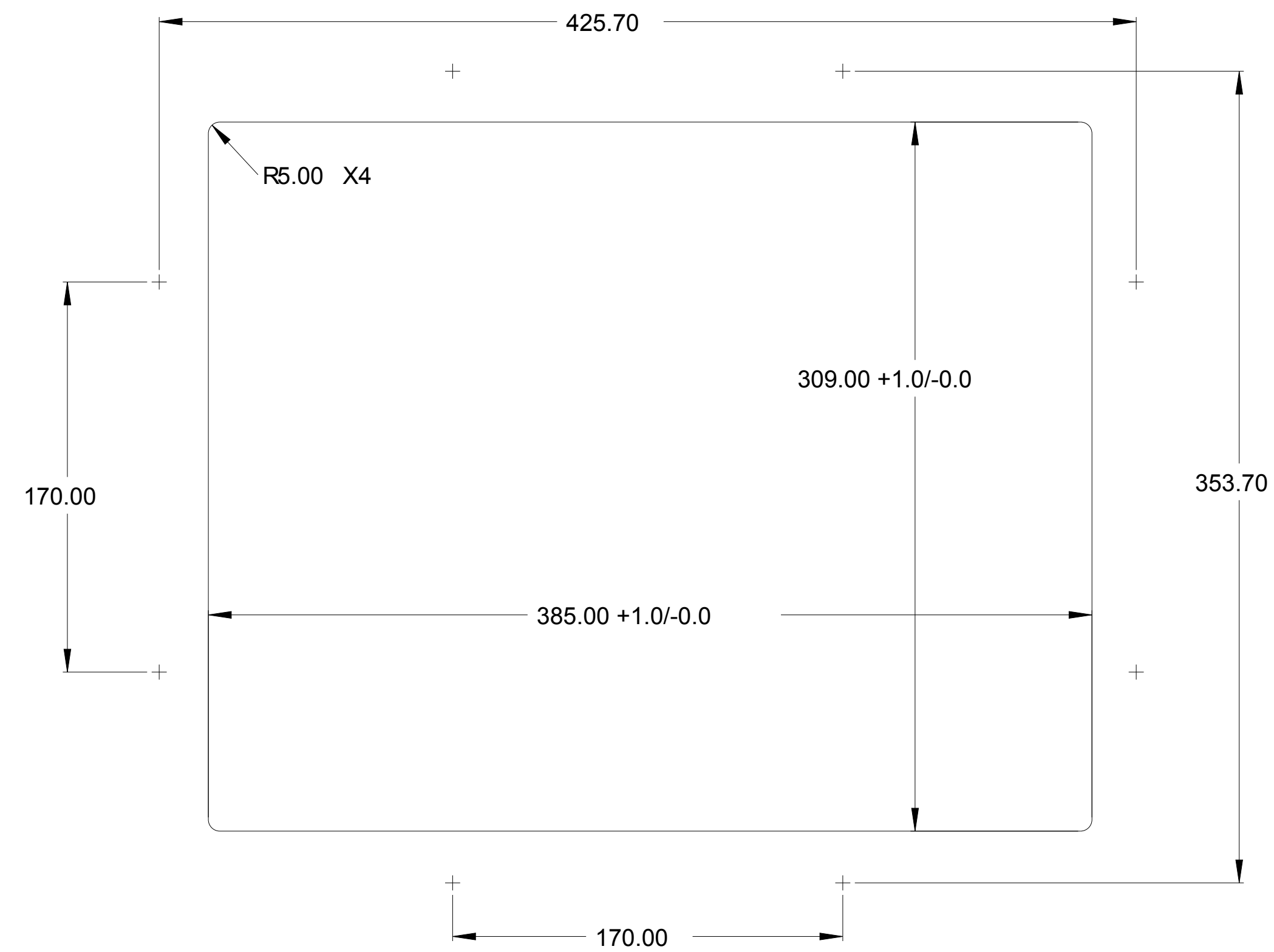

NOTE A
CUSTOMER PANEL MATERIAL:

1. WOOD: \varnothing 4.5 HOLES THRU FOR M4 SCREWS W/NUTS, OR, NO THRU HOLES, SCREWS FOR WOOD \varnothing 4mm
2. SHEET METAL: CONCEALED HEAD THREADED STUDS M4 W/NUTS.

NOTE B
MONITOR INCLUDES 2 BRACKETS. ADDITIONAL BRACKETS AVAILABLE, P/N E147211

NOTE C
33.3mm=SECURE TOUCH
33.2mm=IR
30.2mm=APR

NOTE D
15.9mm=SECURE TOUCH
15.8mm=IR
12.5mm=APR

NOTE E
1.6mm=SECURE TOUCH
1.7mm=IR
5.0mm=APR

VESA MOUNT

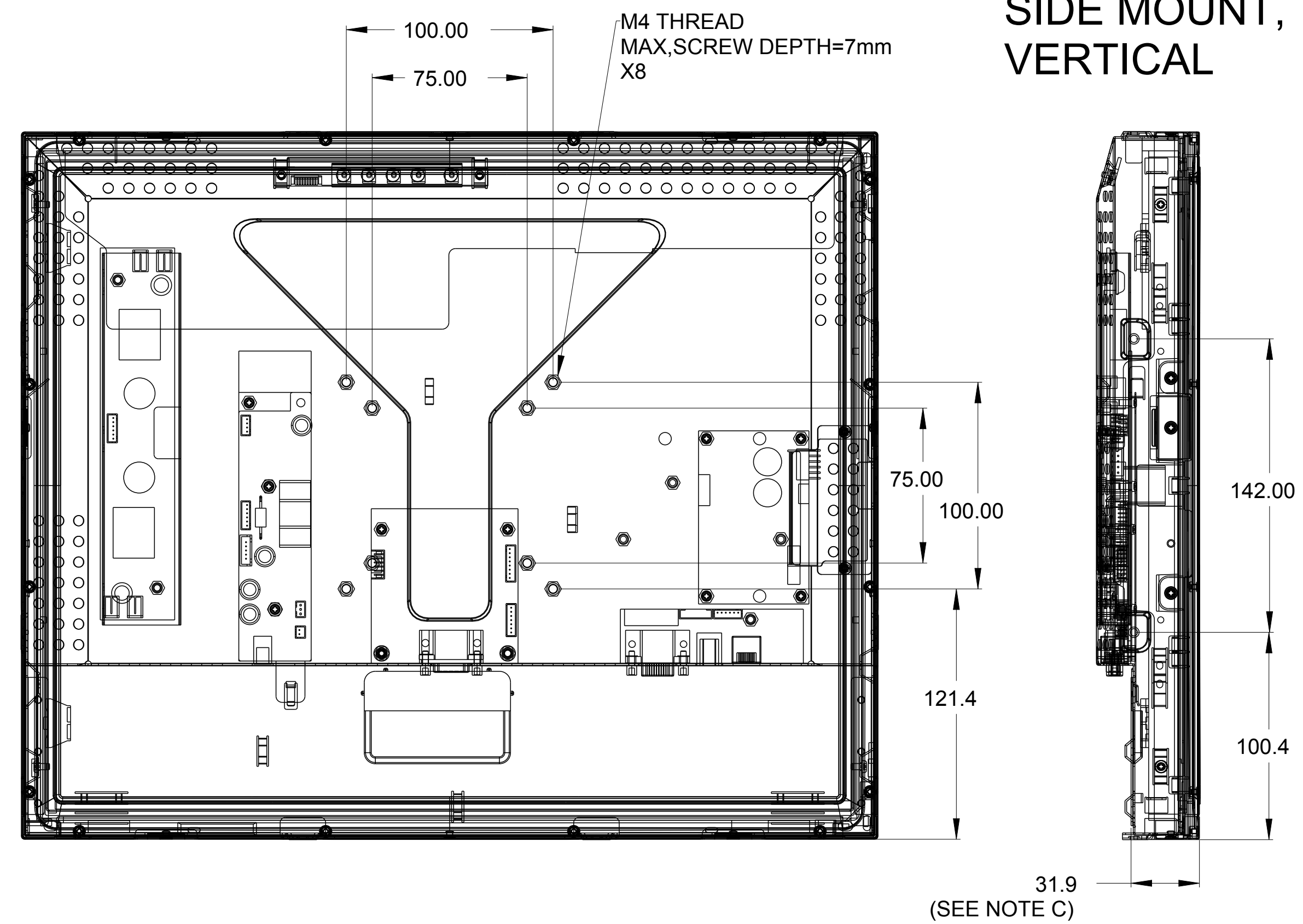

SIDE MOUNT, VERTICAL

REAR MOUNT WITH BRACKETS, HORIZONTAL AND VERTICAL (SEE NOTE B)

MOUNTING BRACKET ADJUSTMENT RANGE

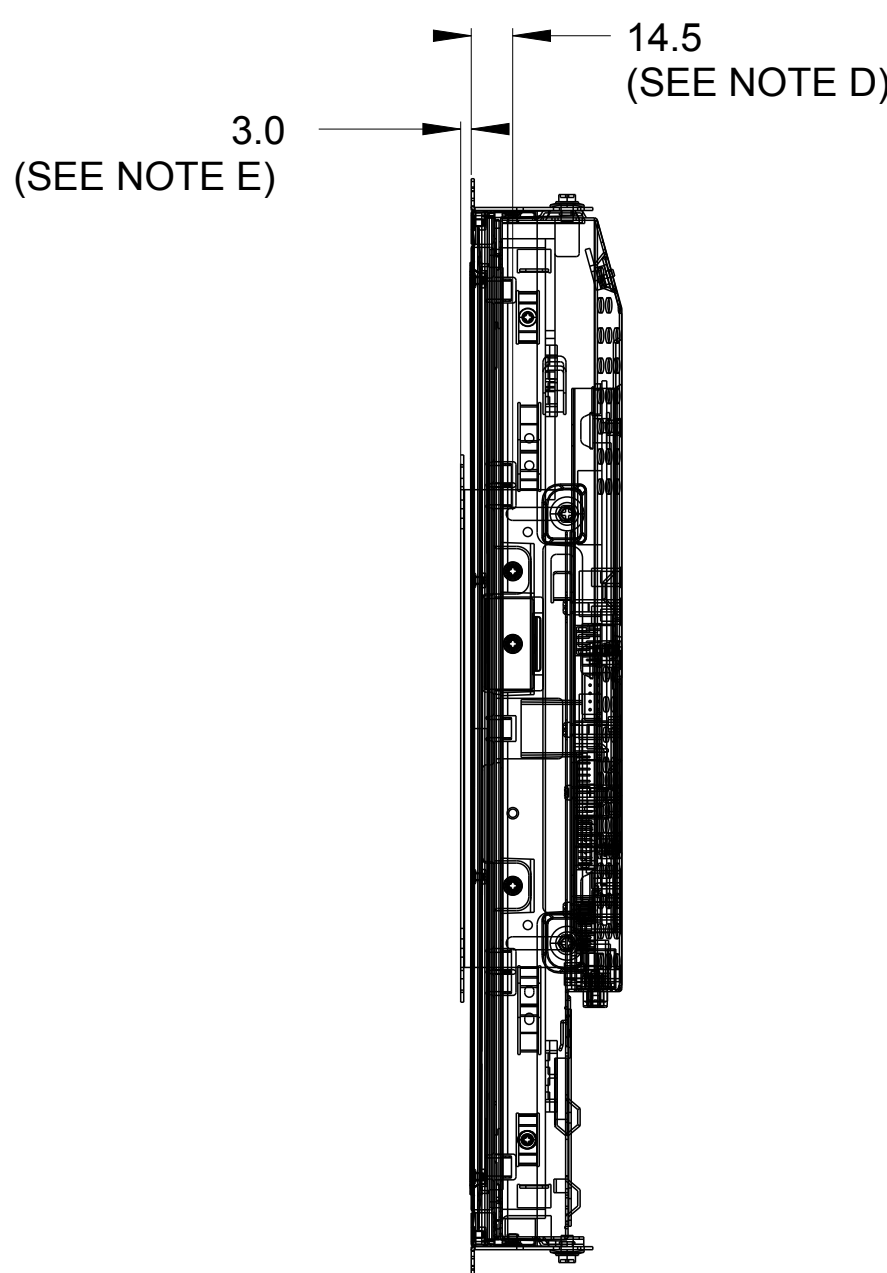

BRACKETS IN HORIZONTAL POSITIONS

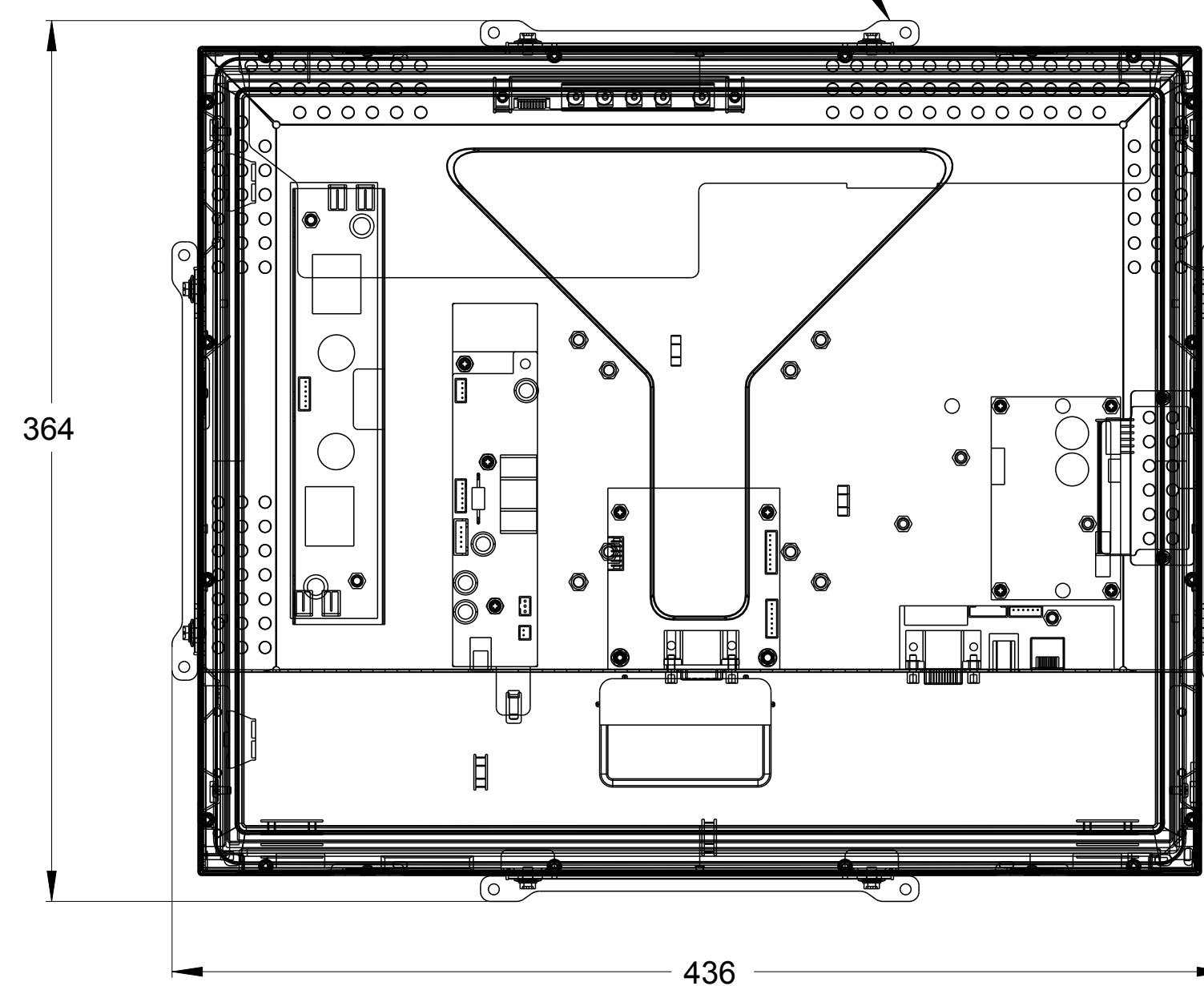

BRACKET IN VERTICAL POSITIONS

SIDE MOUNT, HORIZONTAL

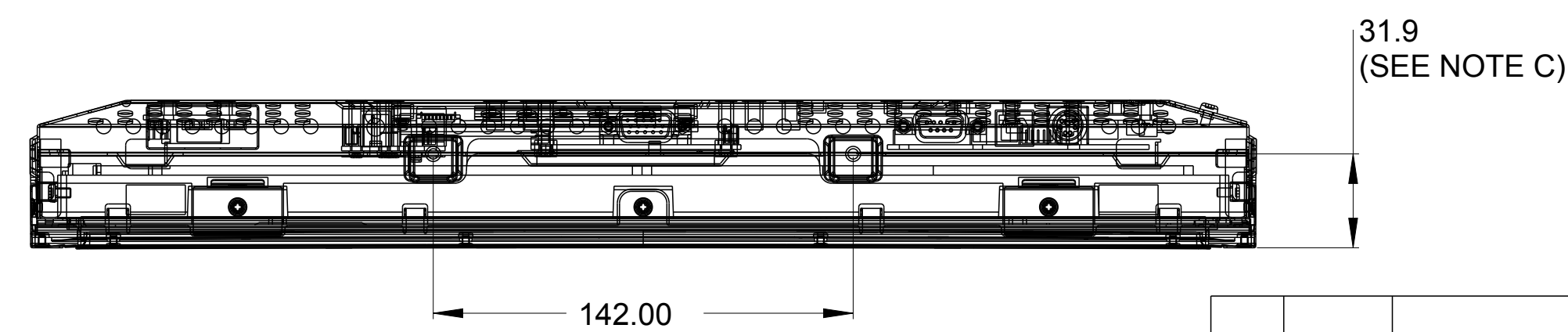

ITEM NO.	QTY REQ'D	DRAWING OR PART NO.	DESCRIPTION	MATERIAL SPECIFICATION
PARTS LIST				
PART. NO.		UNLESS OTHERWISE SPECIFIED ALL DIMENSIONS ARE IN MILLIMETERS	DRAWN -	DATE -
METRIC		TOLERANCES ARE: DECIMALS ANGLES X ± 0.50 ± 1/ 2" X ± 0.25 FRACTIONS XX ± 0.13 ± 1/ 32	CHECK -	DATE -
			DESIGN -	DATE -
DO NOT SCALE DRAWING		THIRD ANGLE PROJECTION		TITLE
Prof/E. prt/asm: MS500786_E_ET1939L_APR.PRT		Prof/E. drw: MS500786_REVH.DRW		DIMENSIONAL DRAWING ET1939L/ ET1937L-XCWA-X
SIZE	SCALE	SHEET	DWG. NO.	REV
D	0.333	6 OF 8	MS500786	H

DWG. NO. MS500786 REV. 6 OF 6

PROPRIETARY TO ELO TOUCH SOLUTIONS, INC. AND SHALL NOT BE DISCLOSED OTHER THAN TO NECESSARY EMPLOYEES OR SUPPLIERS WITHOUT THE EXPRESS WRITTEN CONSENT OF ELO TOUCH SOLUTIONS INC.

REVISIONS					
REV	ZONE	BY	DESCRIPTION	DATE	APPROVED
H	--	BA	SEE SHEET 1	08/31/12	DD

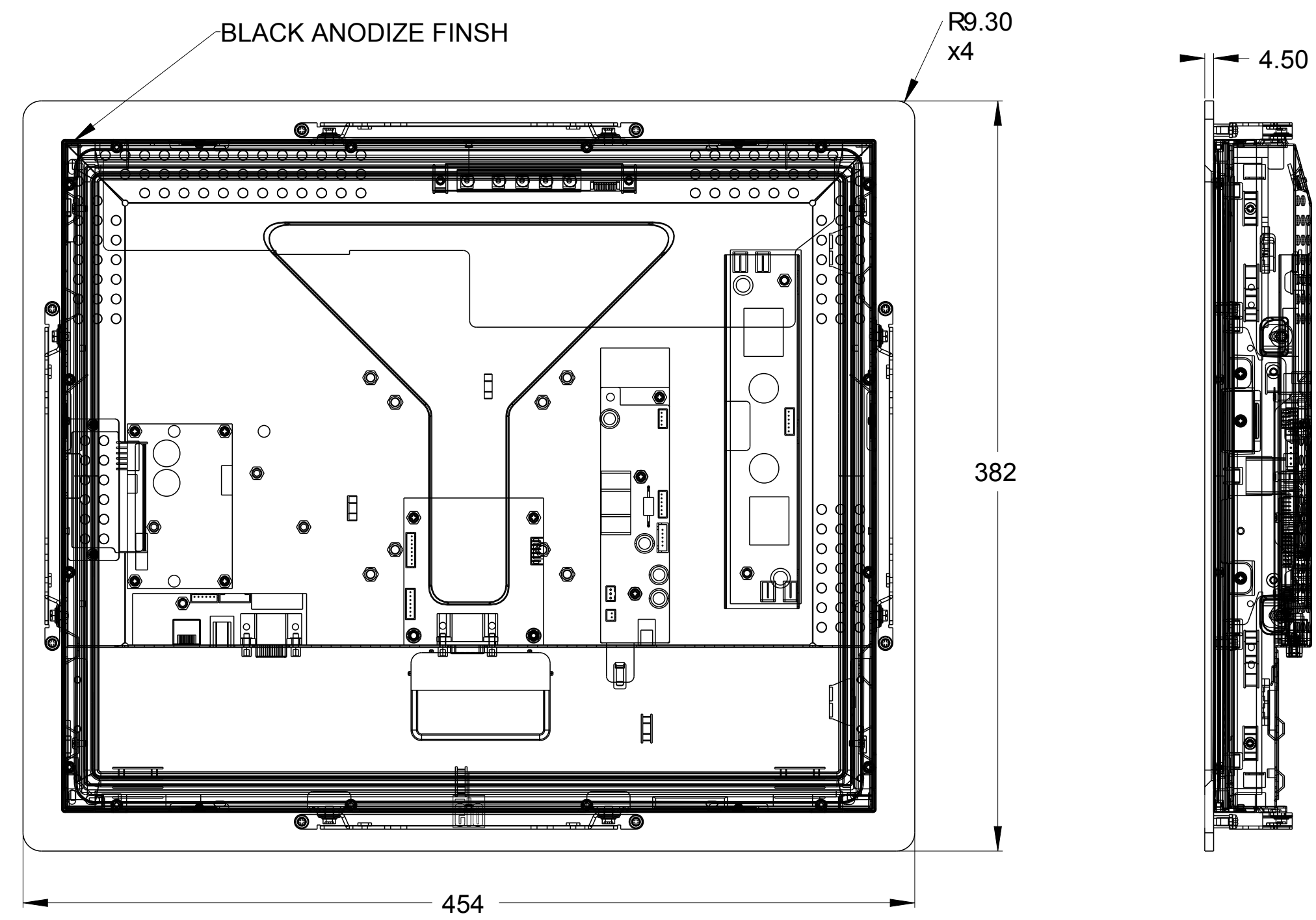

FRONT MOUNT OPTION P/N E163604 (ORDERED SEPERATLY,CUSTOMER ASSEMBLED)

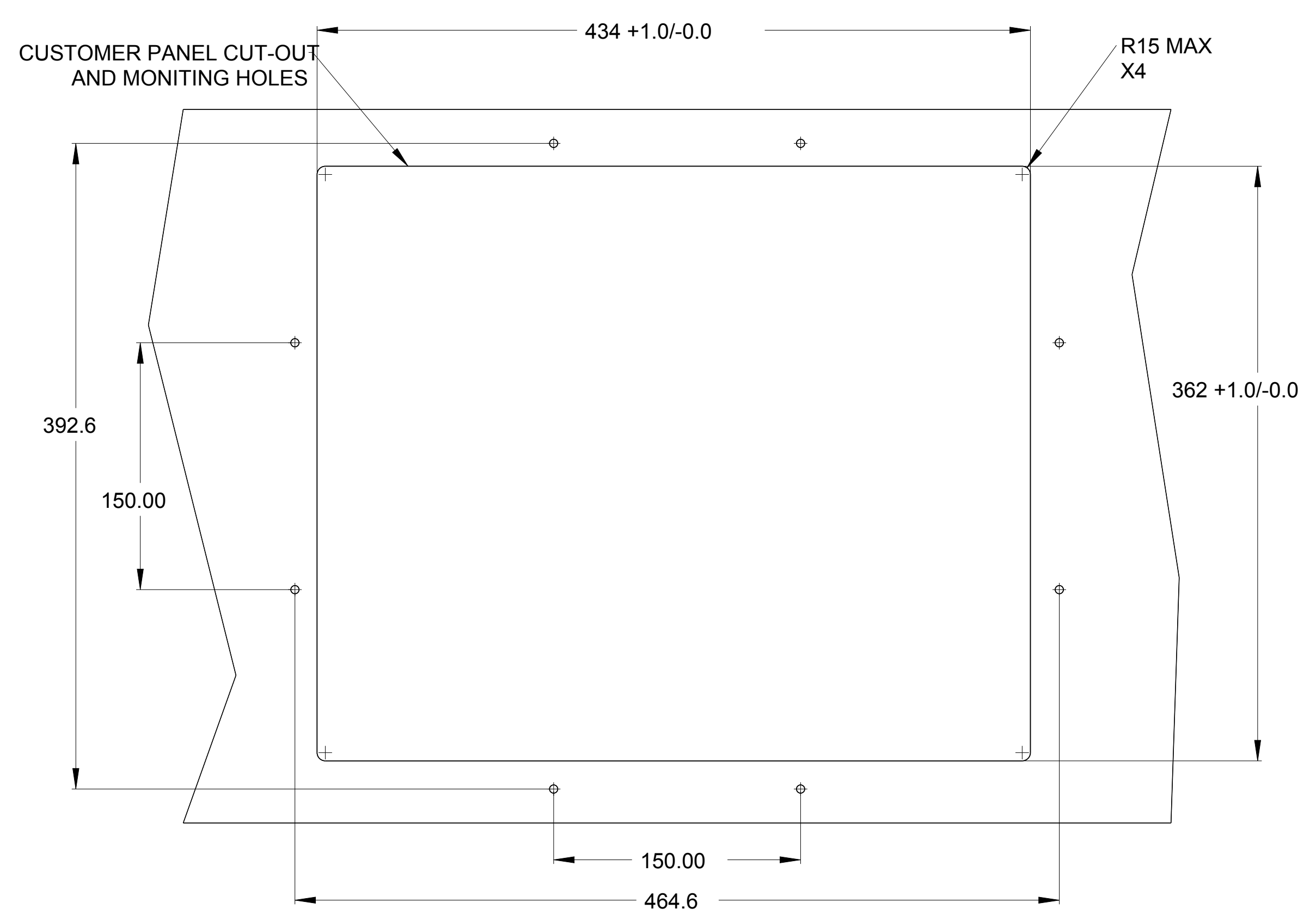
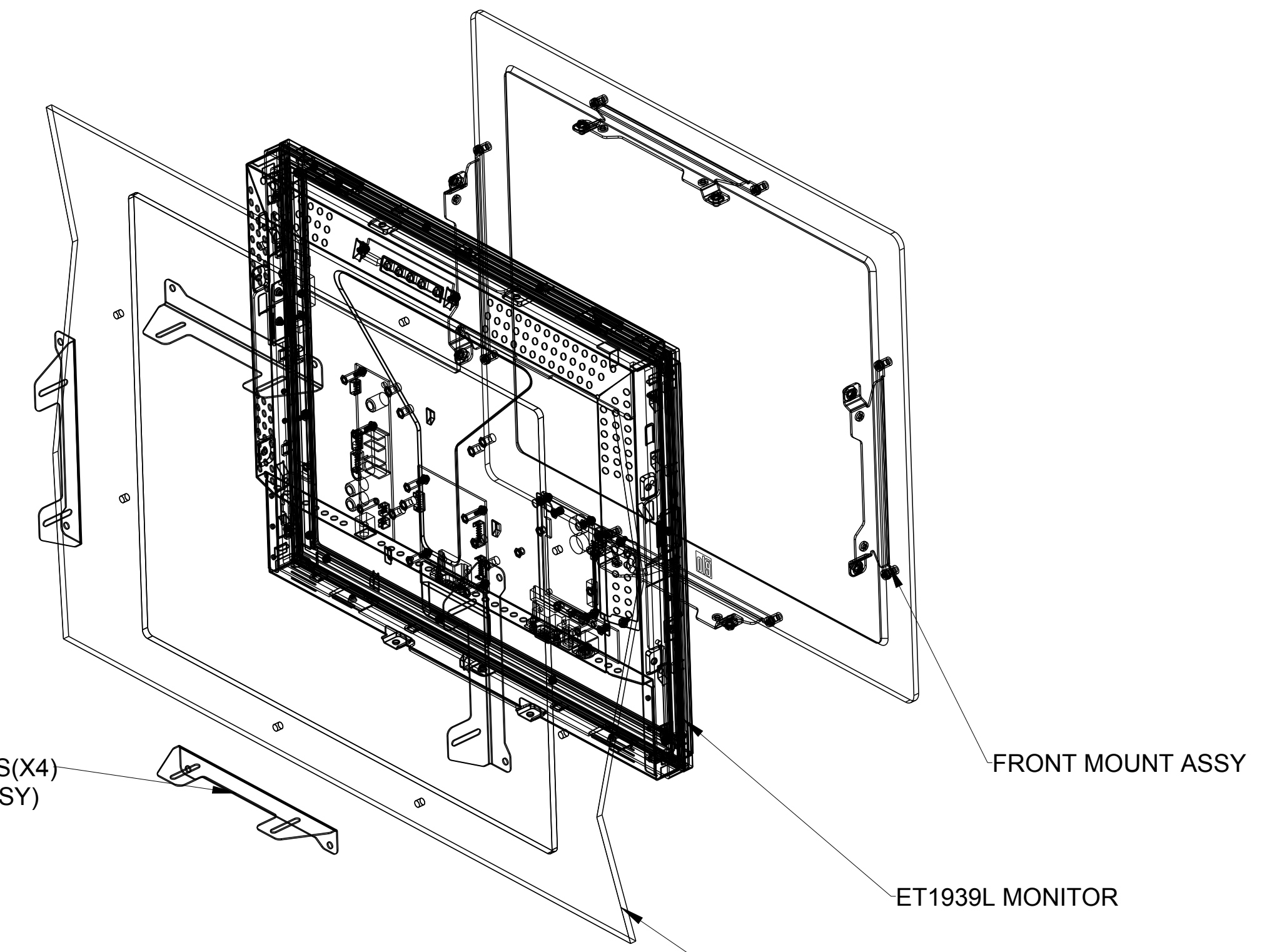

NOTE: 1. IF CUSTOMER PANEL MATERIAL IS WOOD:
Ø 4.5mm HOLES THRU FOR M4 SCREWS, OR NO THRU
HOLES,SCREWS FOR WOOD Ø 4mm. 2.IF CUSTOMER
PANEL MATERIAL IS SHEET METAL: CONCEALED
HEAD THREADED STUDS M4 WITH NUTS

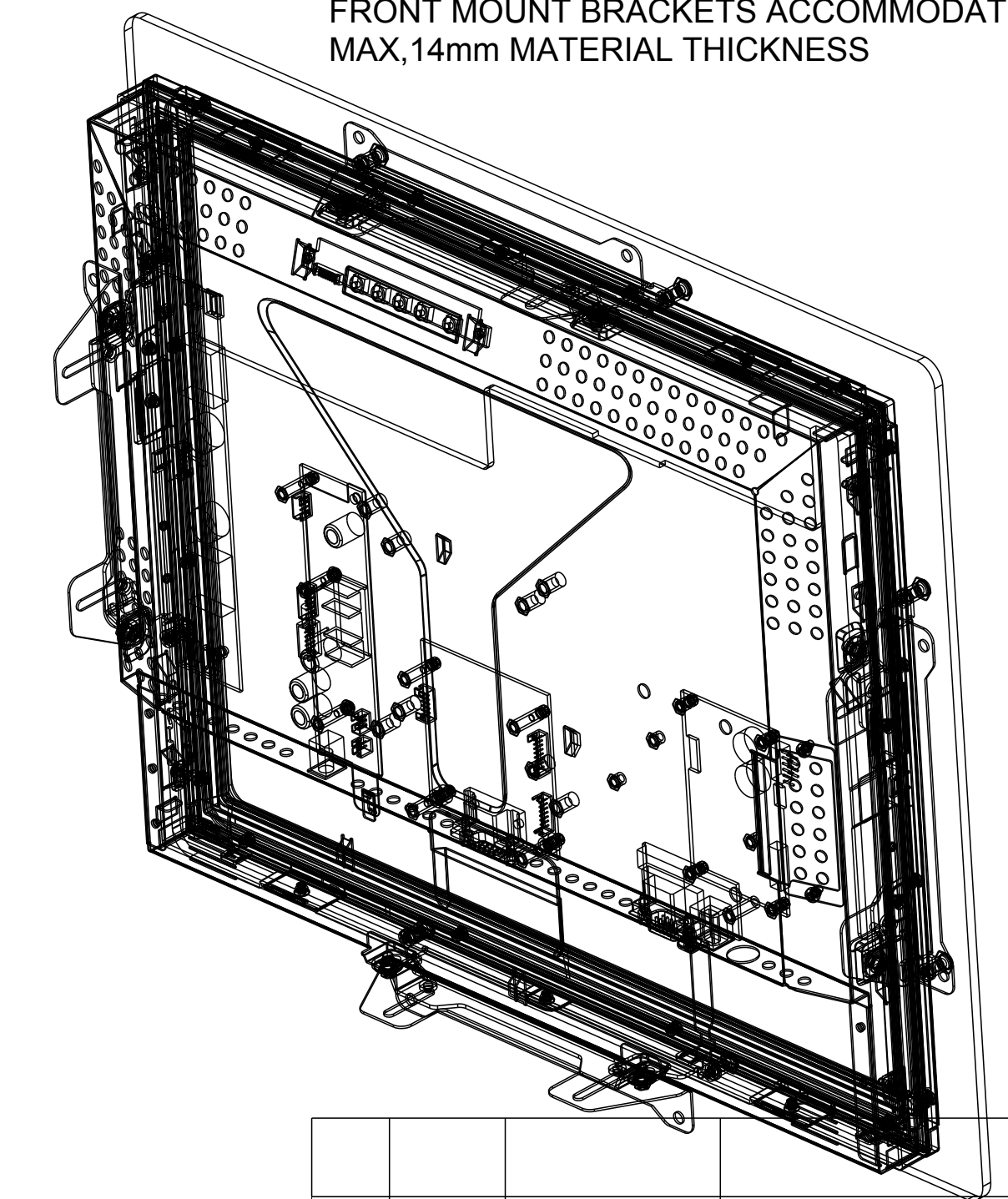
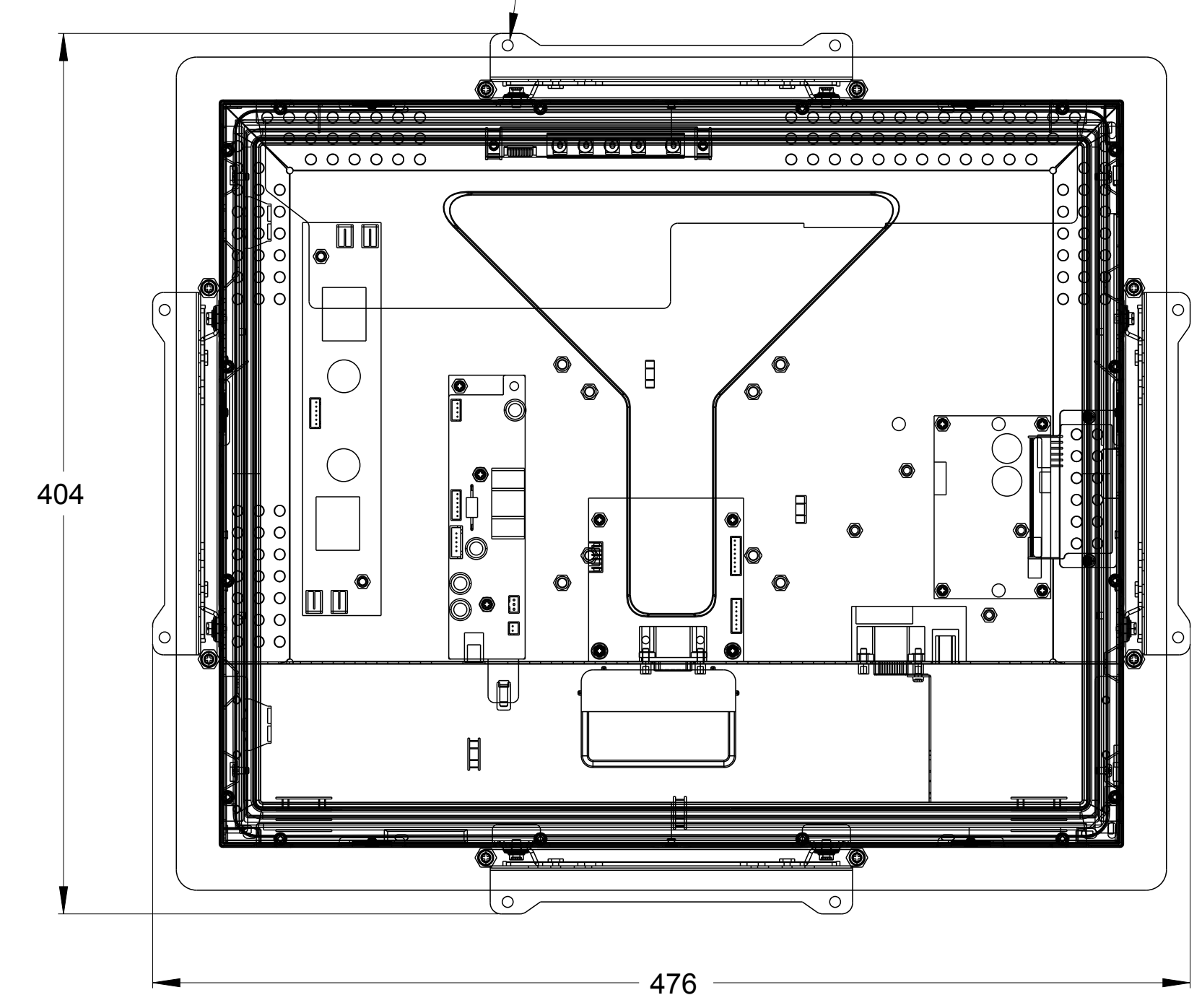

ITEM NO.	QTY REQ'D	DRAWING OR PART NO.	DESCRIPTION	MATERIAL SPECIFICATION
PARTS LIST				
PART. NO.	UNLESS OTHERWISE SPECIFIED ALL DIMENSIONS ARE IN MILLIMETERS	DRAWN - CHECK - DESIGN -	DATE - DATE -	TITLE DIMENSIONAL DRAWING ET1939L/ ET1937L-XCWA-X
METRIC DO NOT SCALE DRAWING Pro/E prt/asm: MS500786_E_ET1939L_APR.PRT Pro/E drw: MS500786_REVH.DRW		TOLERANCES ARE: DECIMALS ±1/ 2" ANGLES ±0.50 FRACTIONS ±1/ 32 XX± 0.13		THIRD ANGLE PROJECTION
SIZE D	SCALE 0.333	SHEET 7 OF 8	DWG. NO. MS500786	REV H

MS500786
SHT 7 OF 8
REV H

PROPRIETARY TO ELO TOUCH SOLUTIONS, INC. AND SHALL NOT BE DISCLOSED OTHER THAN TO NECESSARY EMPLOYEES OR SUPPLIERS WITHOUT THE EXPRESS WRITTEN CONSENT OF ELO TOUCH SOLUTIONS INC.

REVISIONS					
REV	ZONE	BY	DESCRIPTION	DATE	APPROVED
H	--	BA	SEE SHEET 1	08/31/12	DD

RACK MOUNT OPTION P/N E579652

(ORDERED SEPERATLY,CUSTOMER ASSEMBLED)

BLACK ANODIZE FINISH

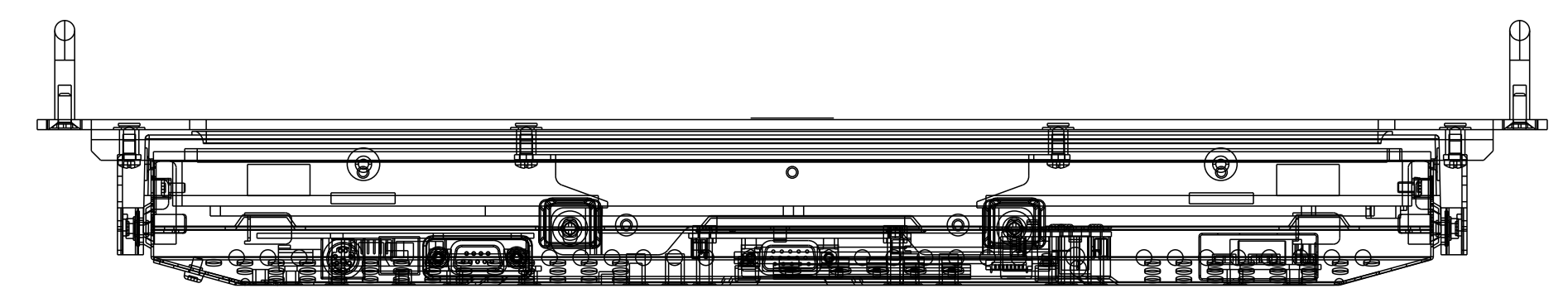
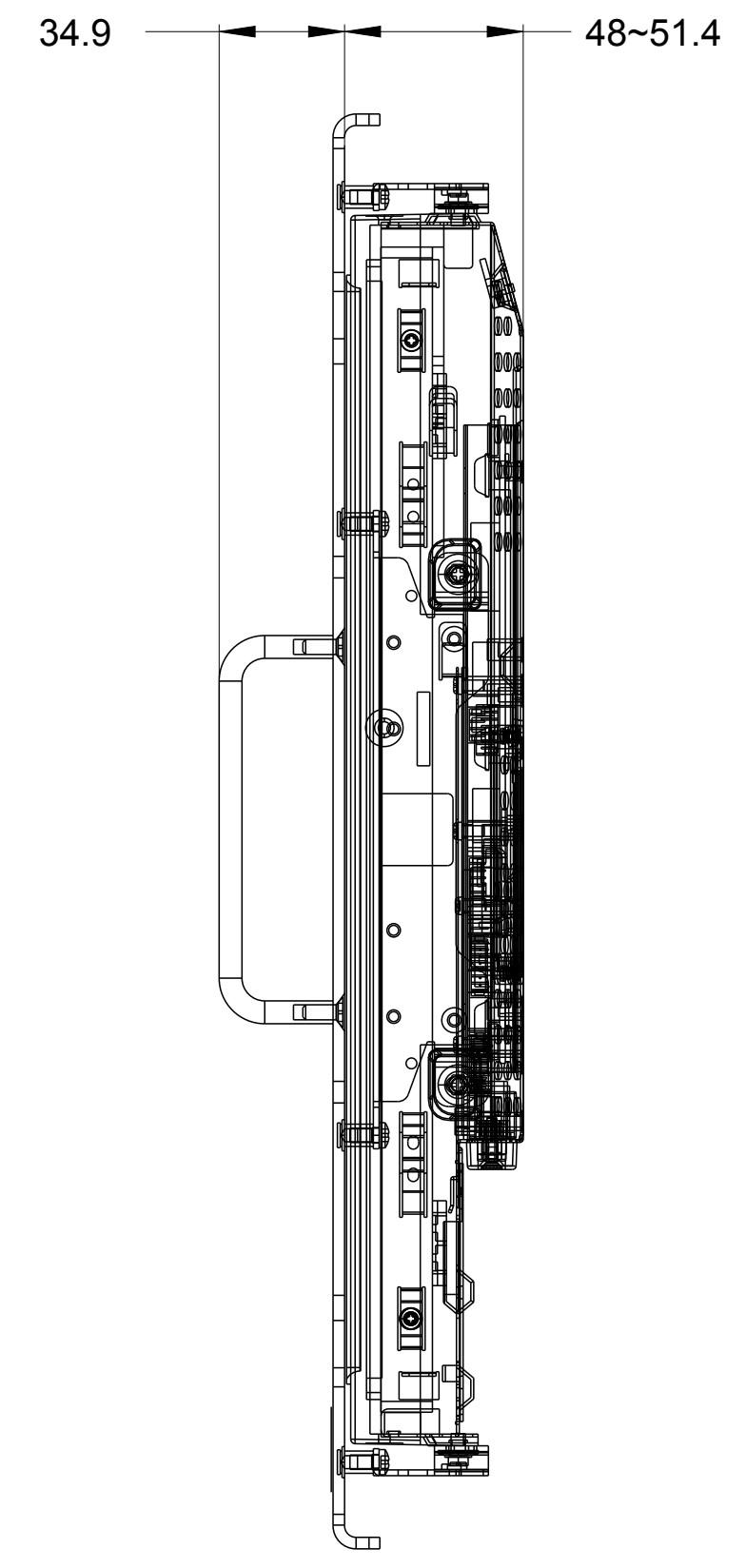
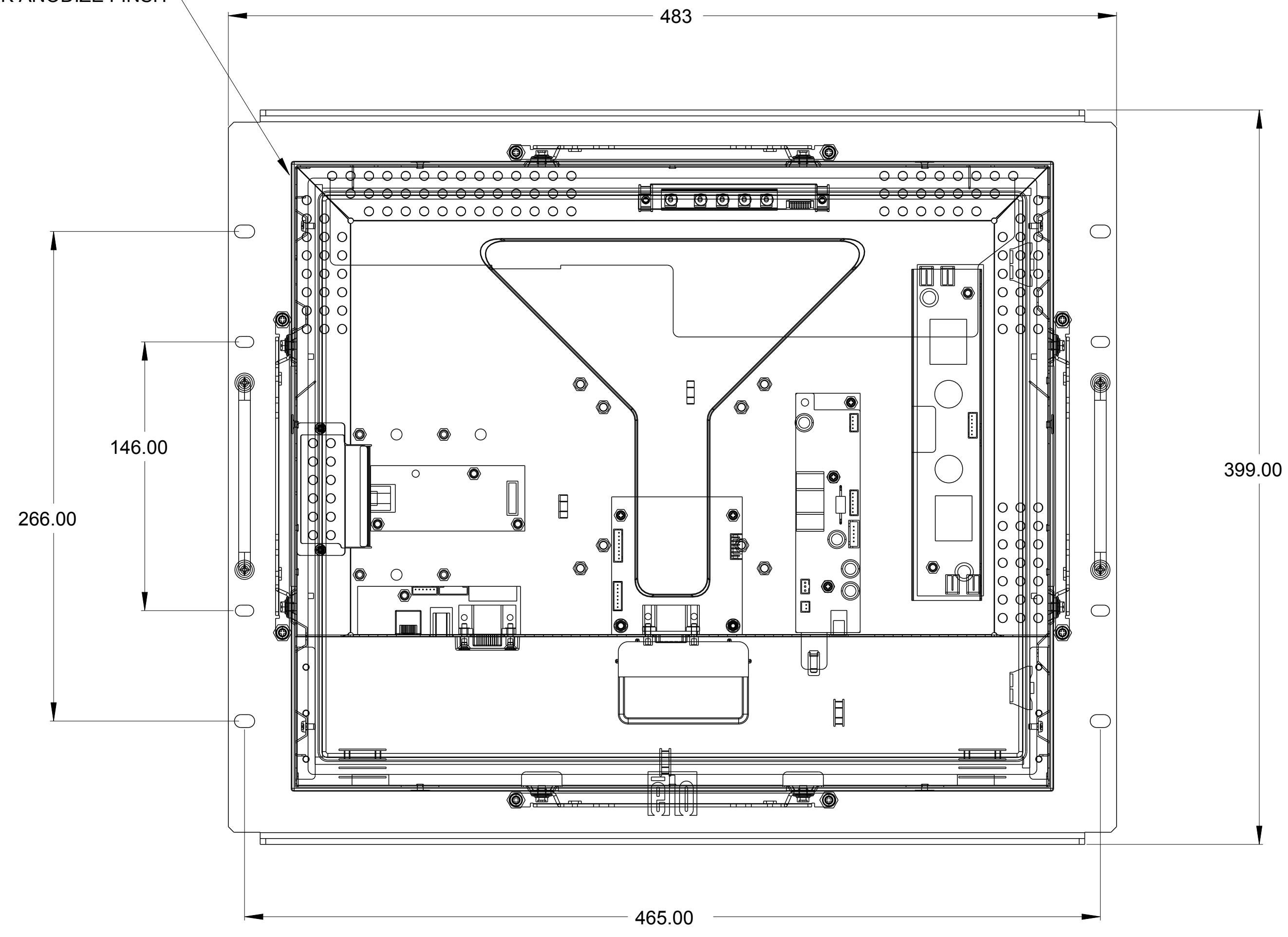

ITEM NO.	QTY REQ'D	DRAWING OR PART NO.	DESCRIPTION	MATERIAL SPECIFICATION
PARTS LIST				
PART. NO.		UNLESS OTHERWISE SPECIFIED ALL DIMENSIONS ARE IN MILLIMETERS	DRAWN KEN NORTH-	DATE -
METRIC		TOLERANCES ARE:	CHECK	DATE
		DECIMALS ±1/ 2"	DESIGN	DATE
DO NOT SCALE DRAWING		ANGLES ±1/ 32"	THIRD ANGLE PROJECTION	
Pro/E prt/asm: MS500786_E_ET1939L_APR.PRT		FRACTIONS ±1/ 32"		
Pro/E drw: MS500786_REVH.DRW				
SIZE	SCALE	SHEET	DWG. NO.	REV
D	0.333	8 OF 8	MS500786	H

DWG. NO. MS500786

REV 8 OF 8

REV H