

PROPRIETARY TO ELO TOUCH SOLUTIONS, INC. AND SHALL NOT BE DISCLOSED OTHER THAN TO NECESSARY EMPLOYEES OR SUPPLIERS WITHOUT THE EXPRESS WRITTEN CONSENT OF ELO TOUCH SOLUTIONS, INC.

REVISIONS					
REV	ZONE	BY	DESCRIPTION	DATE	APPROVED
A	--	KJN	INITIAL RELEASE	05/31/10	
B	--	DI	REVISED PER ECO-12-016378, ELO TITLE BLOCK WAS TE	09/25/12	

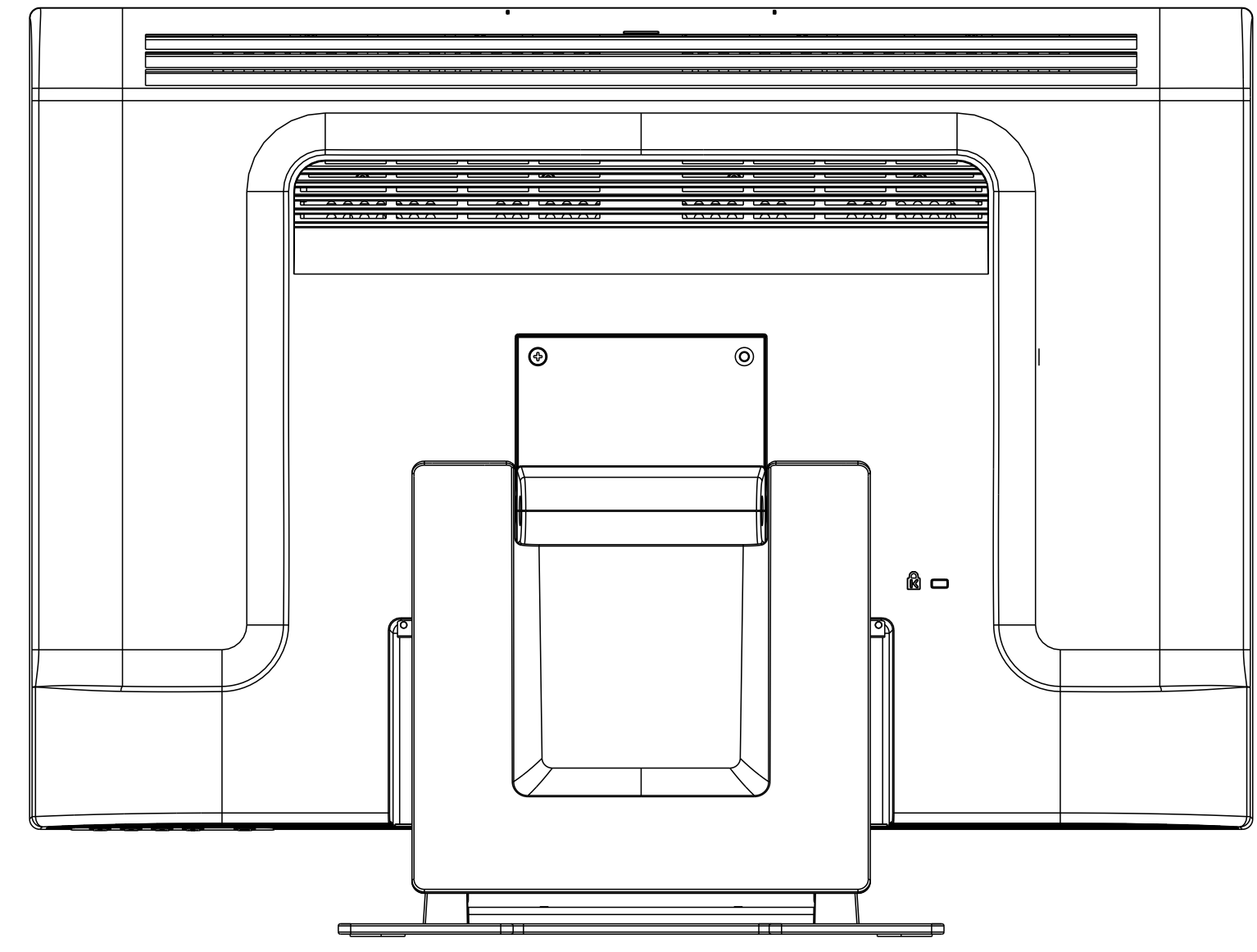
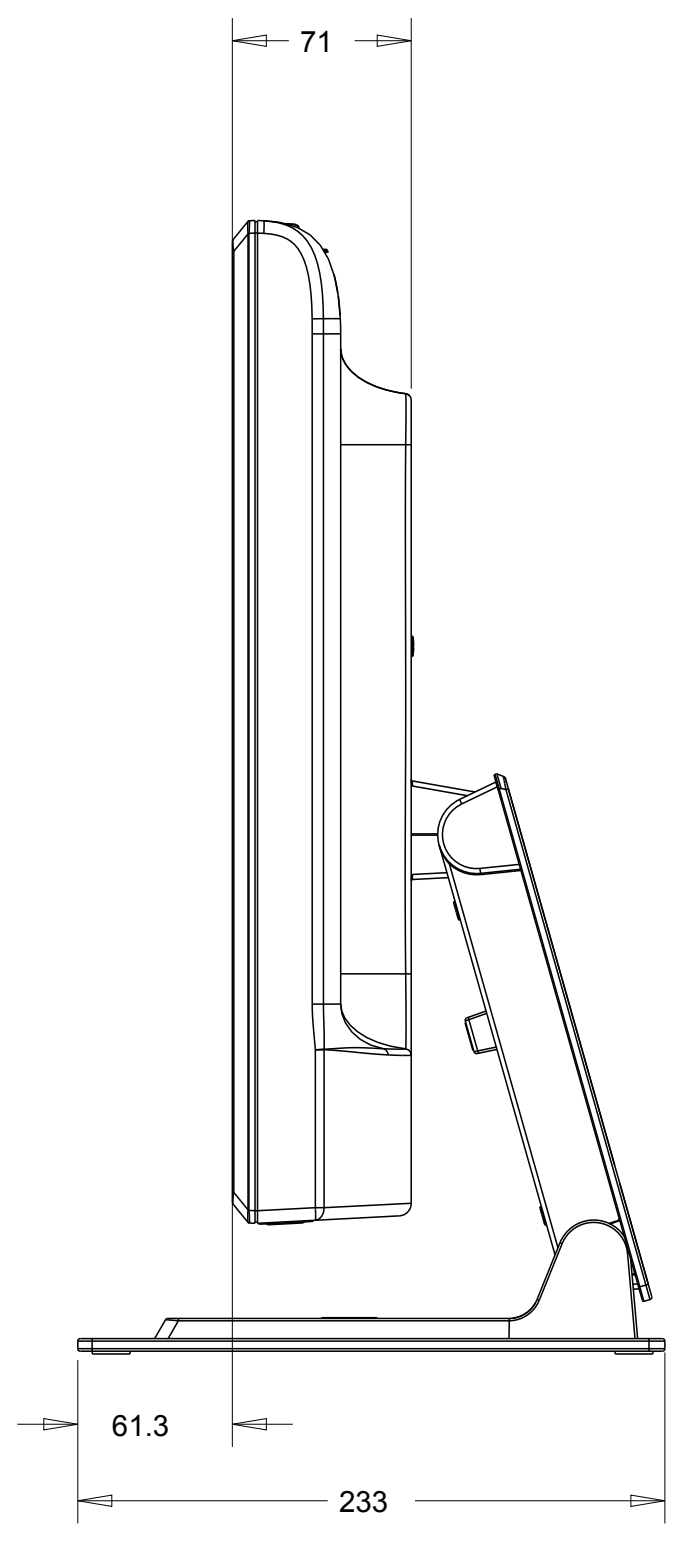
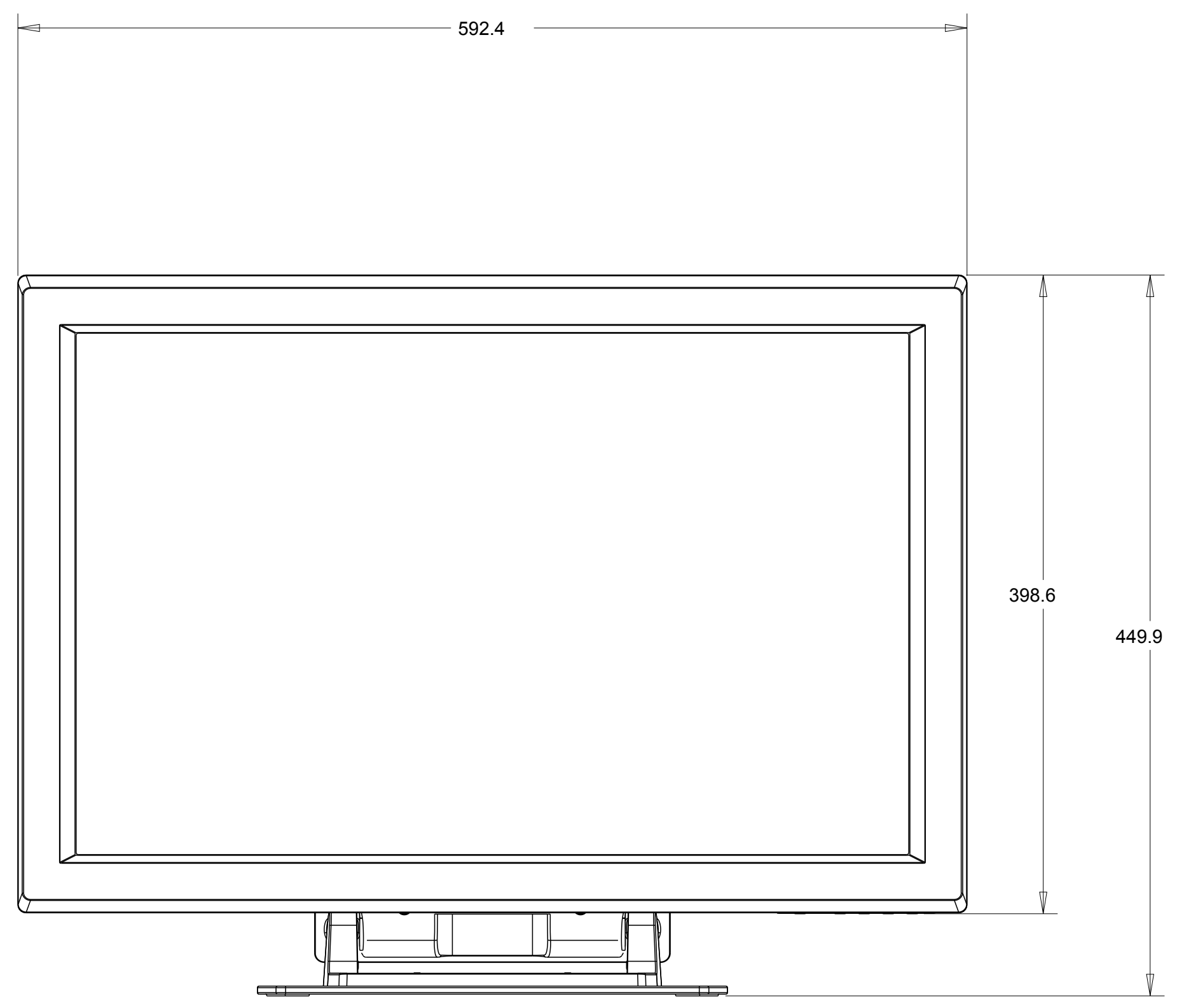
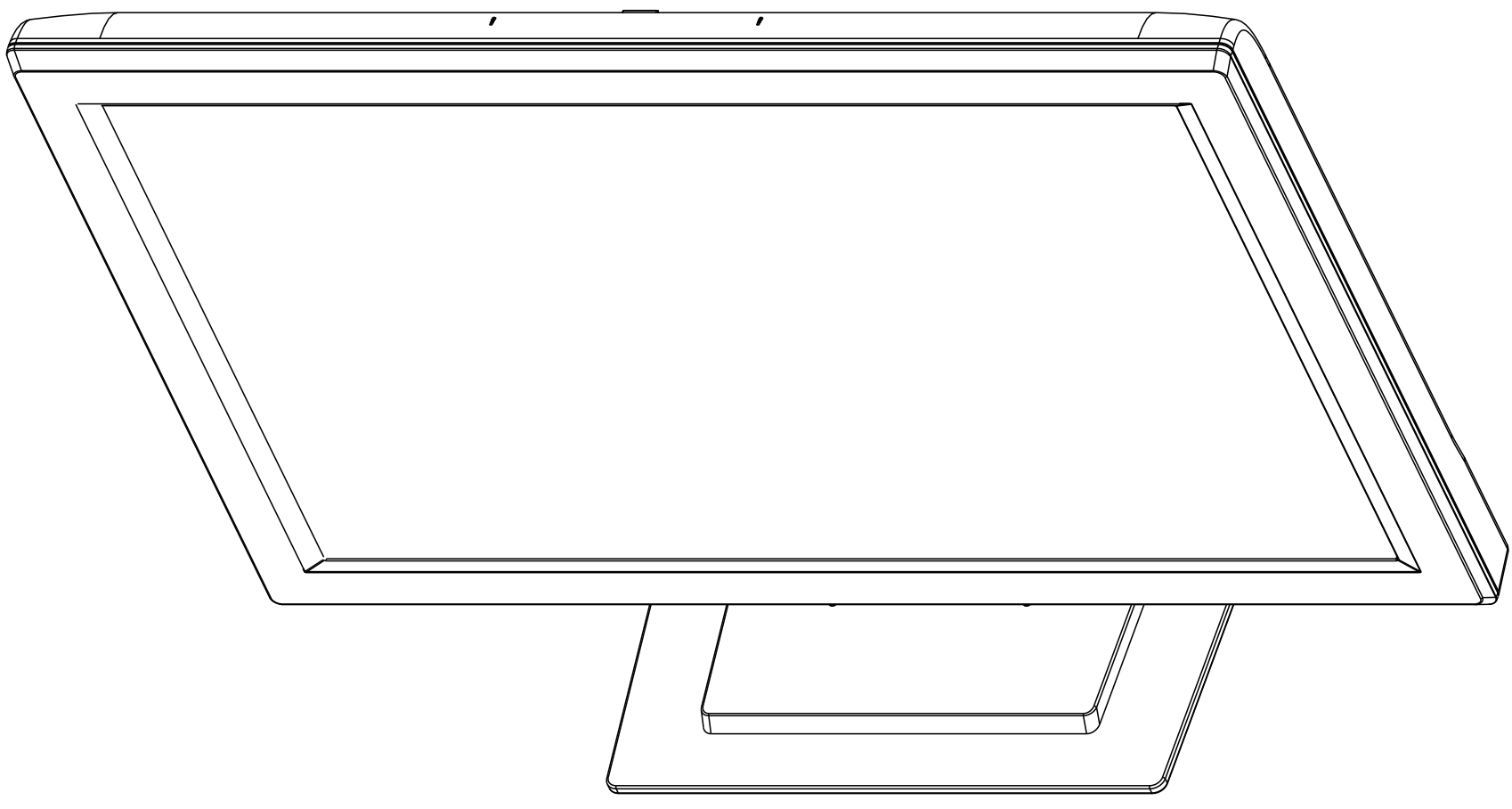
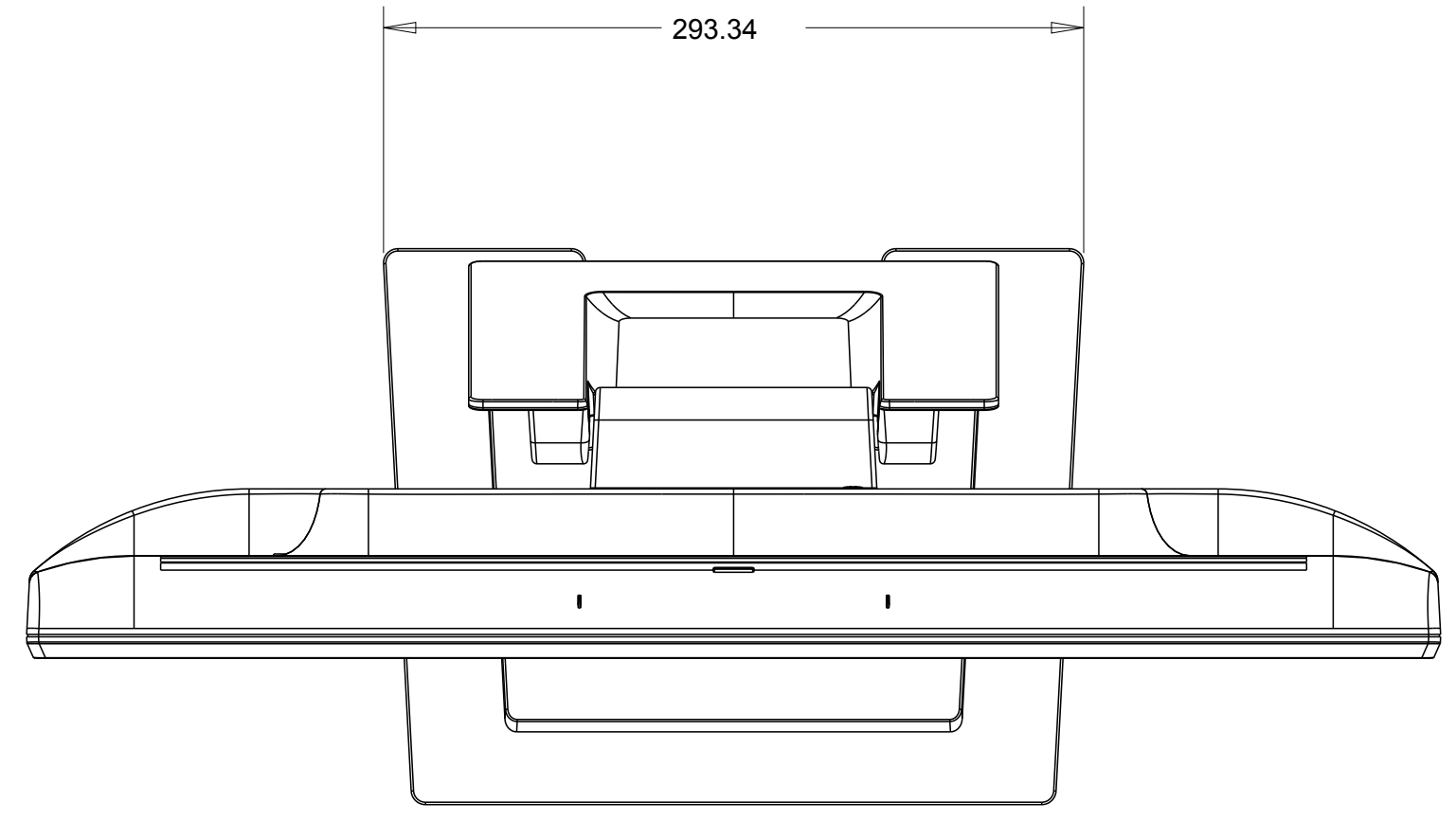

ITEM NO.	QTY REQ'D	DRAWING OR PART NO.	DESCRIPTION	MATERIAL SPECIFICATION
PARTS LIST				
PART. NO.		DRAWN		DATE
UNLESS OTHERWISE SPECIFIED ALL DIMENSIONS ARE IN MILLIMETERS		KEN NORTH		00.00.00
TOLERANCES ARE:		CHECK		DATE
DECIMALS		DESIGN		DATE
ANGLES		KEN NORTH		00.00.00
X ±: 0.50		THIRD ANGLE PROJECTION		
X ±: 0.25				
XX ±: 0.13				
DO NOT SCALE DRAWING				
ProfE_prt.asm: 100_MONITOR_HEAD.PRT				
ProfE_dwg: MS600932_REV8.DRW				
SIZE	SCALE	SHEET	DWG. NO.	REV
D	7:60	1 OF 3	MS600932	B

DIMENSIONAL
DRAWING
ET2400LM



DWG. NO. MS600932

PROPRIETARY TO ELO TOUCH SOLUTIONS, INC. AND SHALL NOT BE DISCLOSED OTHER THAN TO NECESSARY EMPLOYEES OR SUPPLIERS WITHOUT THE EXPRESS WRITTEN CONSENT OF ELO TOUCH SOLUTIONS, INC.

REVISIONS					
REV	ZONE	BY	DESCRIPTION	DATE	APPROVED
			SEE SHEET ONE		

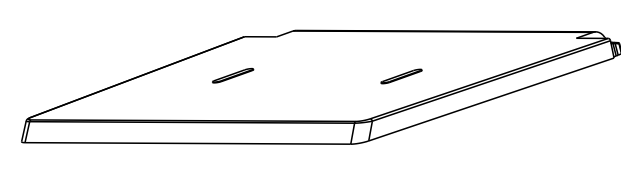
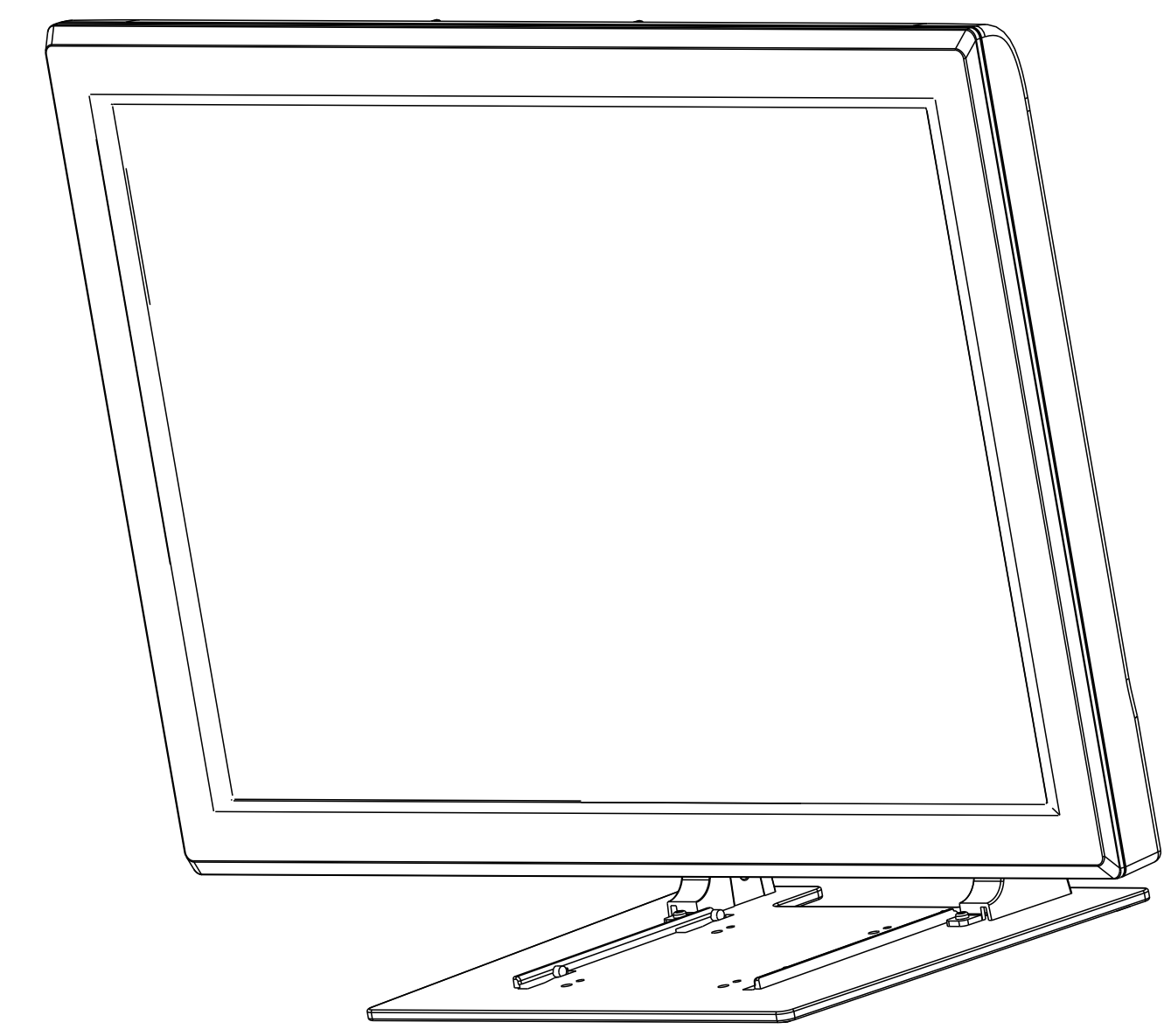

SANP OFF STAND COVER TO MOUNT STAND WITH OPTION 1.

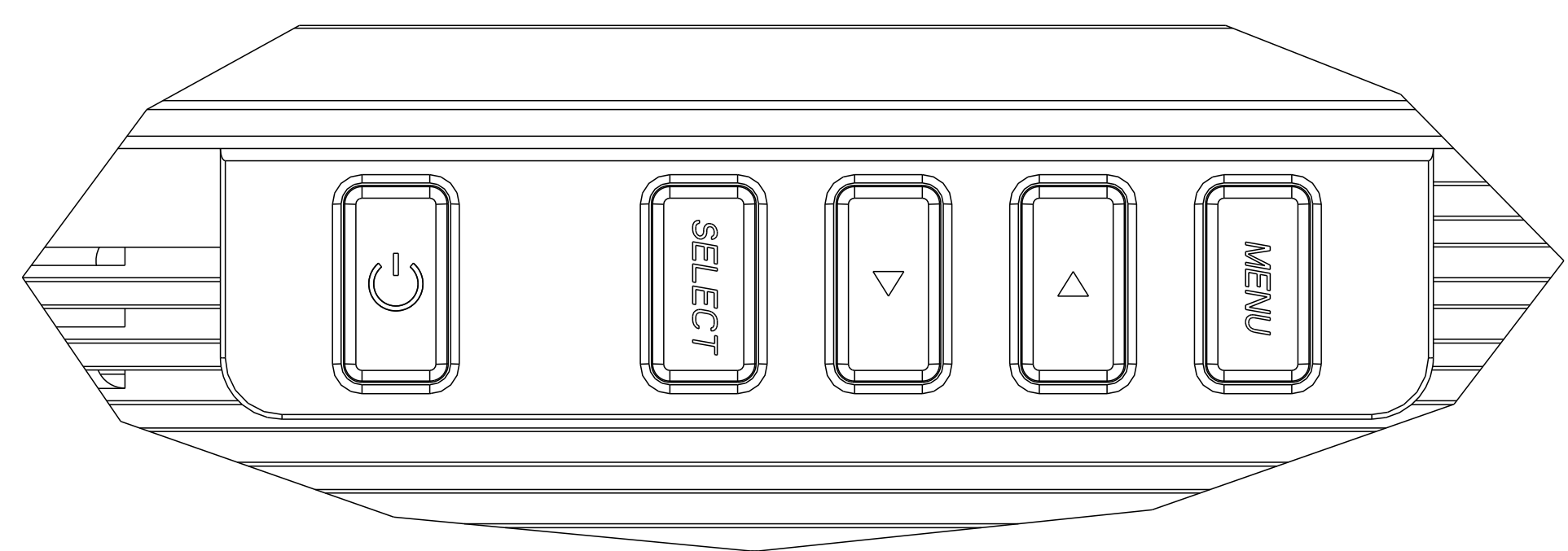

DETAIL A
OSD CONTROL

MOUNT OPTION 1

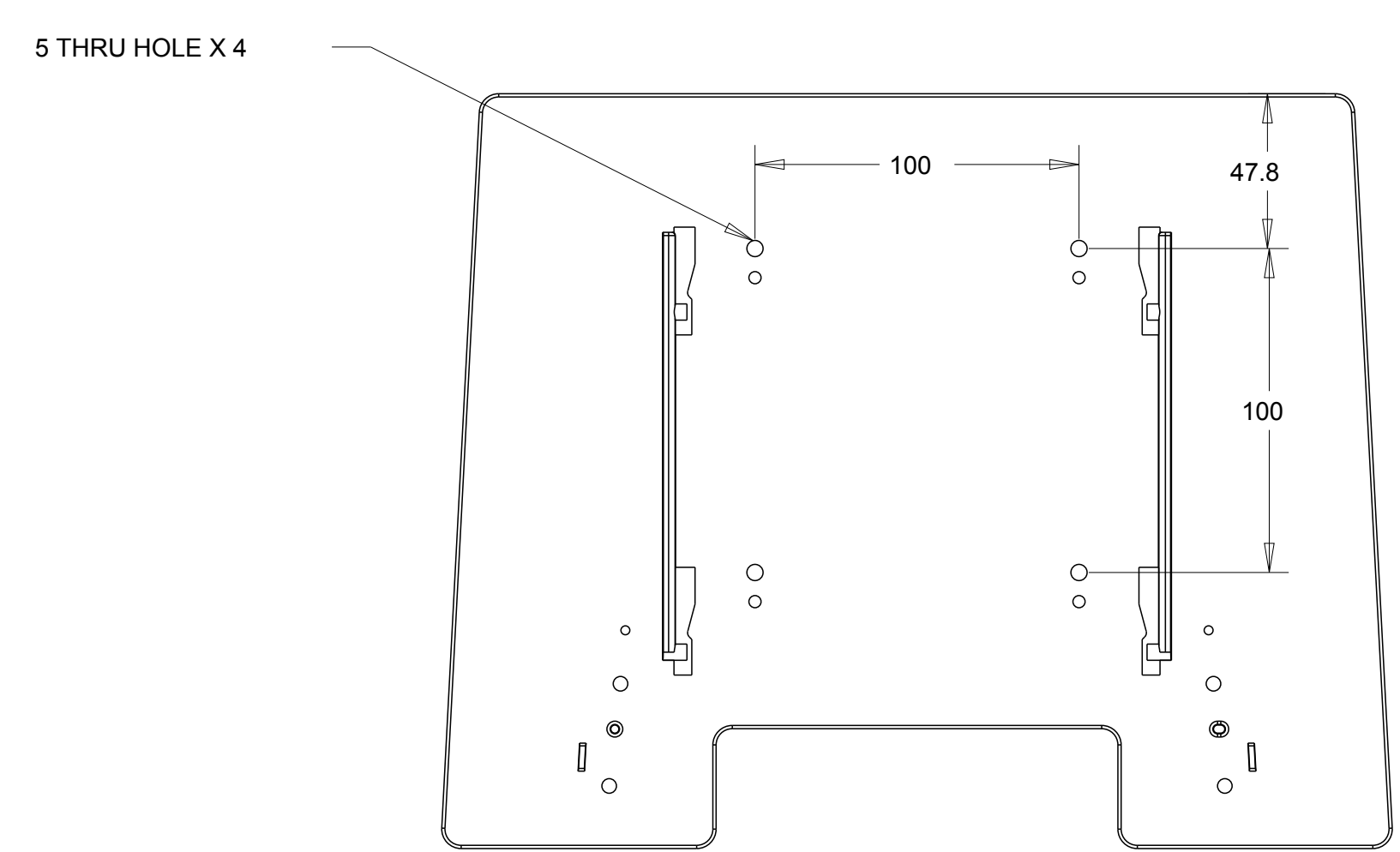

TOP VIEW

MOUNT OPTION 2

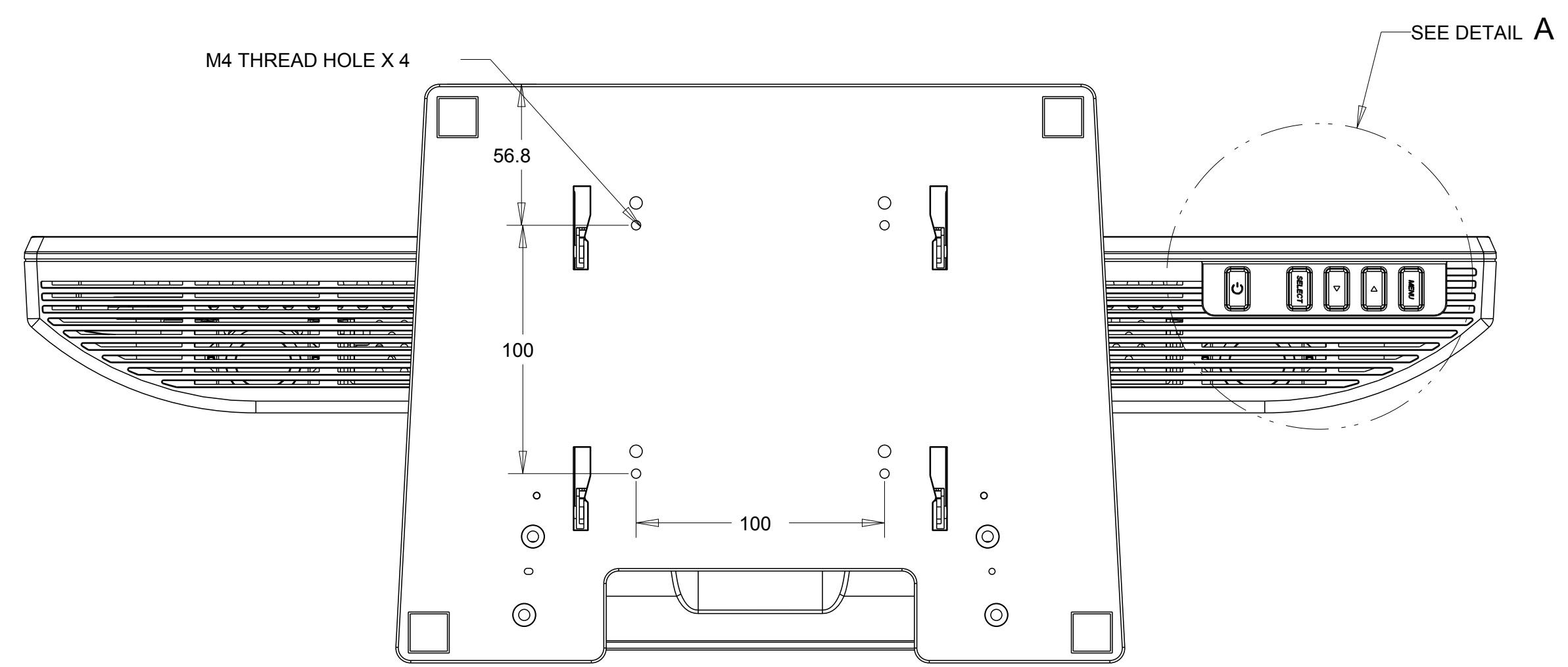

BOTTOM VIEW

ITEM NO.	QTY REQ'D	DRAWING OR PART NO.	DESCRIPTION	MATERIAL SPECIFICATION
PARTS LIST				
PART. NO.		DRAWN KEN NORTH		DATE 00.00.00
UNLESS OTHERWISE SPECIFIED ALL DIMENSIONS ARE IN MILLIMETERS		CHECK		DATE
TOLERANCES ARE:		DESIGN		DATE
DECIMALS ±1/2°		KEN NORTH		00.00.00
X ±: 0.50		THIRD ANGLE PROJECTION		
X ±: 0.25				
XX ±: 0.13				
DO NOT SCALE DRAWING		SIZE D	SCALE 7:60	SHEET 2 OF 3
ProfE_prt.asm 100_MONITOR_HEAD.PRT ProfE_dwg MS600932_REV8.DRW		DWG. NO. MS600932	REV B	

TITLE
DIMENSIONAL
DRAWING
ET4200LM



DWG. NO. MS600932

PROPRIETARY TO ELO TOUCH SOLUTIONS, INC. AND SHALL NOT BE DISCLOSED OTHER THAN TO NECESSARY EMPLOYEES OR SUPPLIERS WITHOUT THE EXPRESS WRITTEN CONSENT OF ELO TOUCH SOLUTIONS, INC.

REVISIONS					
REV	ZONE	BY	DESCRIPTION	DATE	APPROVED
			SEE SHEET ONE		

VESA MOUNT

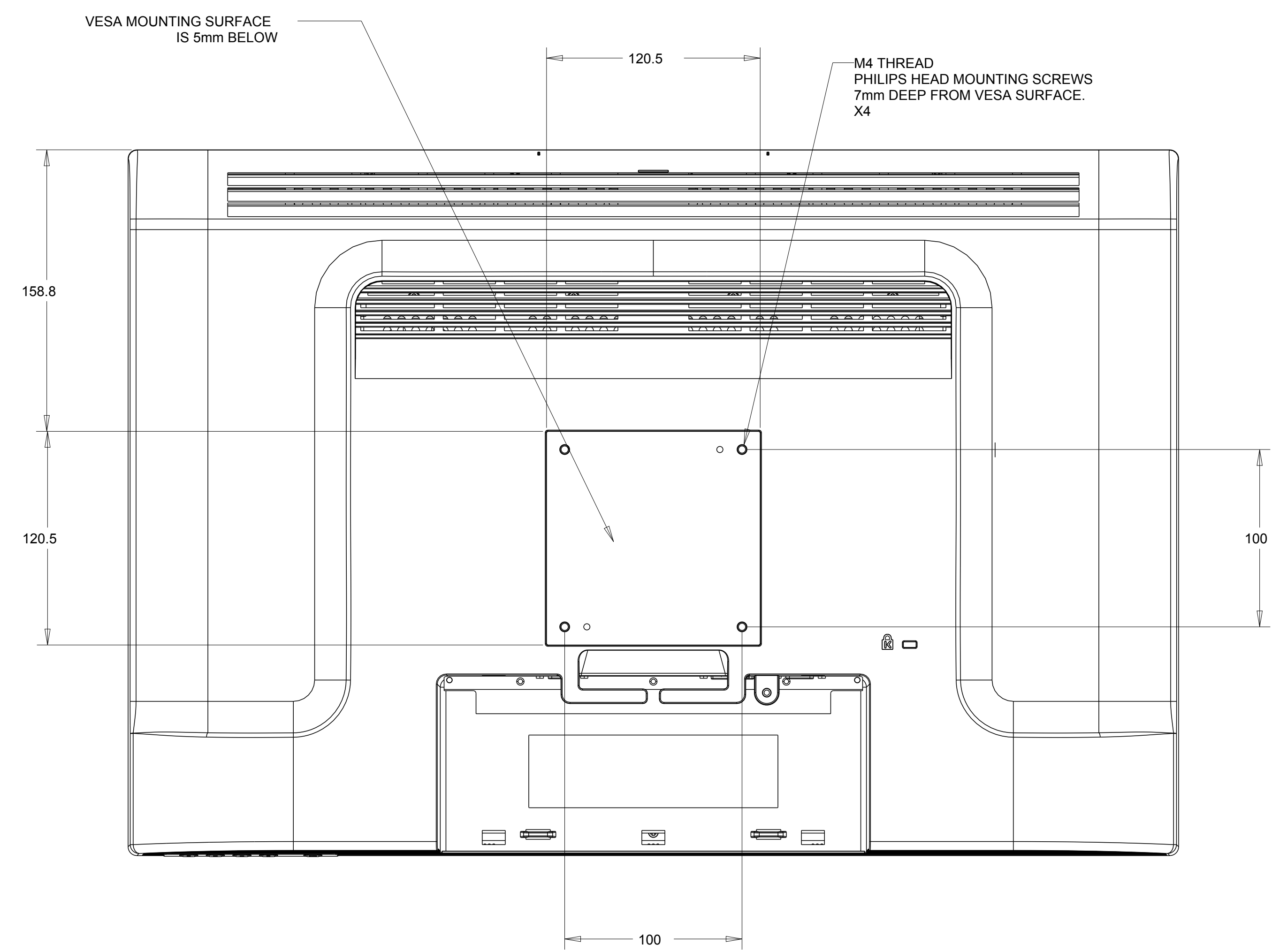

CONNECTOR PANEL

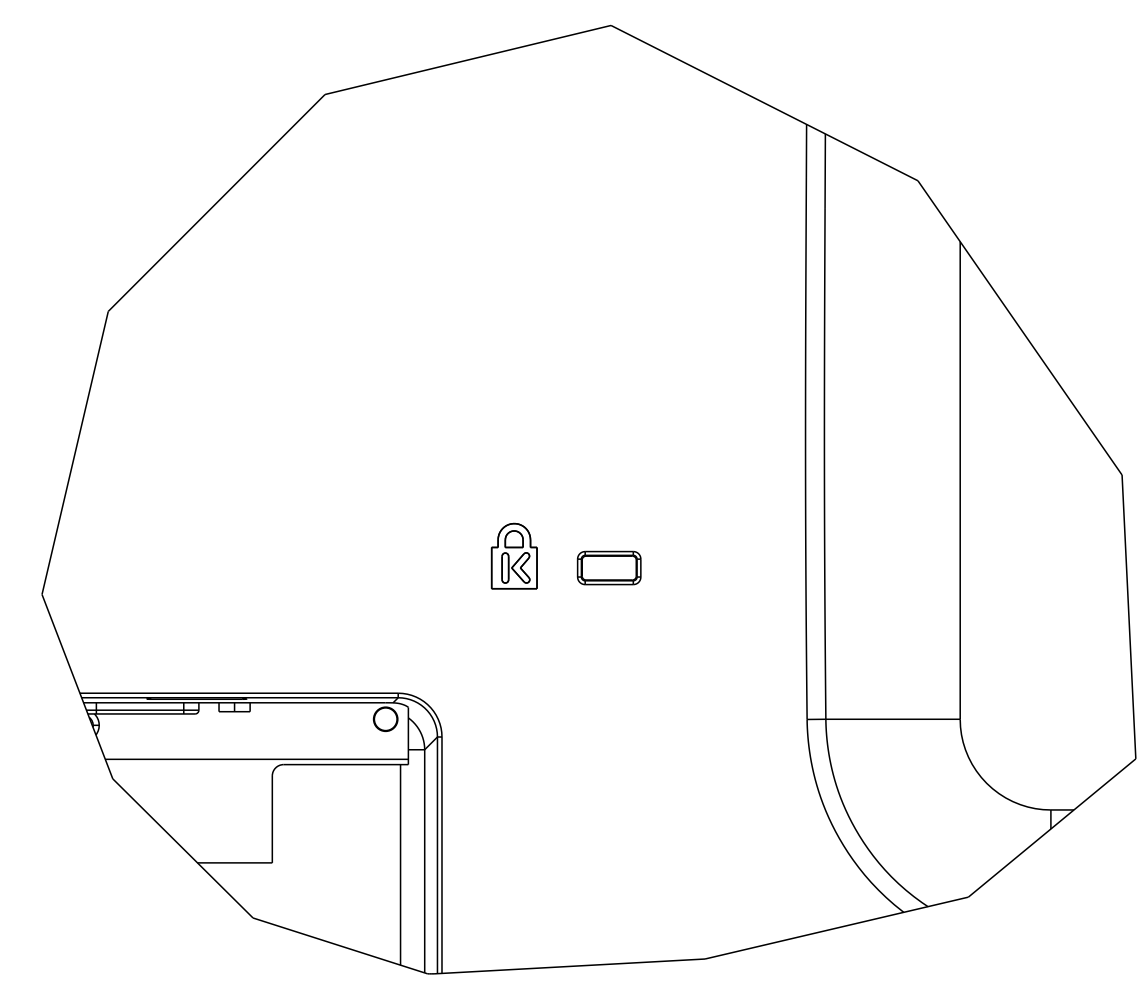
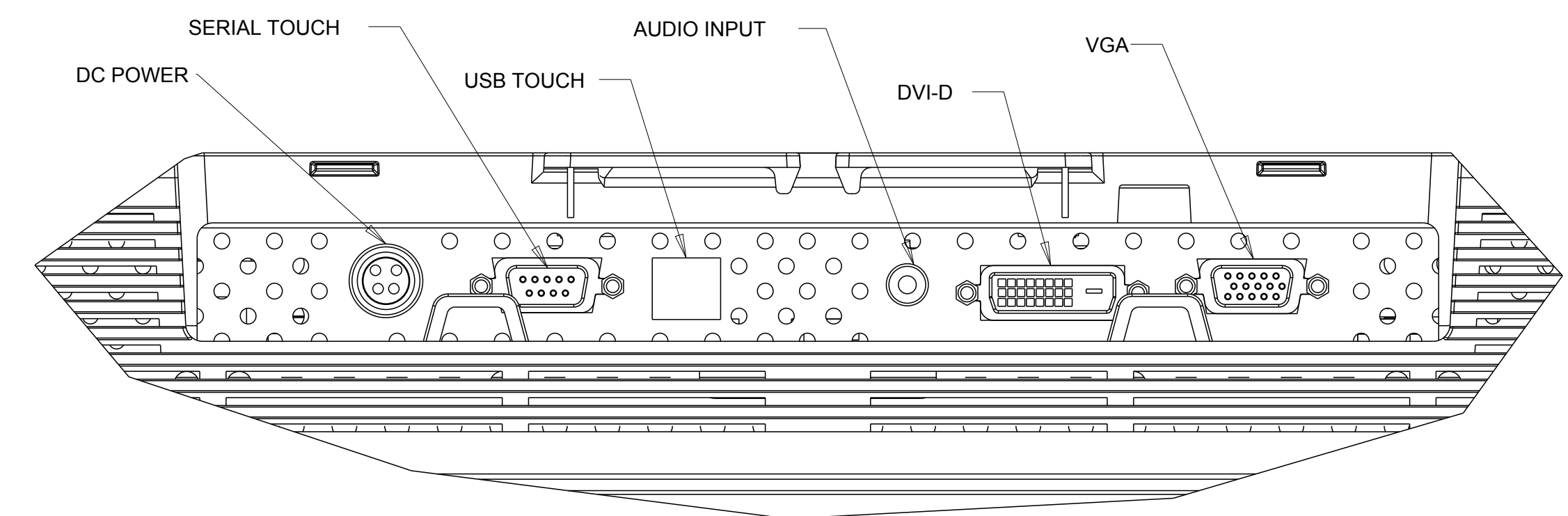

ITEM NO.	QTY REQ'D	DRAWING OR PART NO.	DESCRIPTION	MATERIAL SPECIFICATION
PARTS LIST				
PART. NO.		UNLESS OTHERWISE SPECIFIED ALL DIMENSIONS ARE IN MILLIMETERS	DRAWN KEN NORTH	DATE 00.00.00
METRIC		TOLERANCES ARE:	CHECK	DATE
DO NOT SCALE DRAWING		DECIMALS ± 1/2 ²	DESIGN KEN NORTH	DATE 00.00.00
ProfE_prt.asm: 100_MONITOR_HEAD.PRT		ANGLES ± 1/2 ²	THIRD ANGLE PROJECTION	
ProfE_dwg: MS600932_REV8.DRW		FRACTIONS ± 1/32		
SIZE	SCALE	SHEET	DWG. NO.	REV
D	7:60	3 OF 3	MS600932	B

TITLE
DIMENSIONAL
DRAWING
ET4200LM



DWG. NO. MS600932