

MKTG DWG, ET1587C-XXWA-1-G

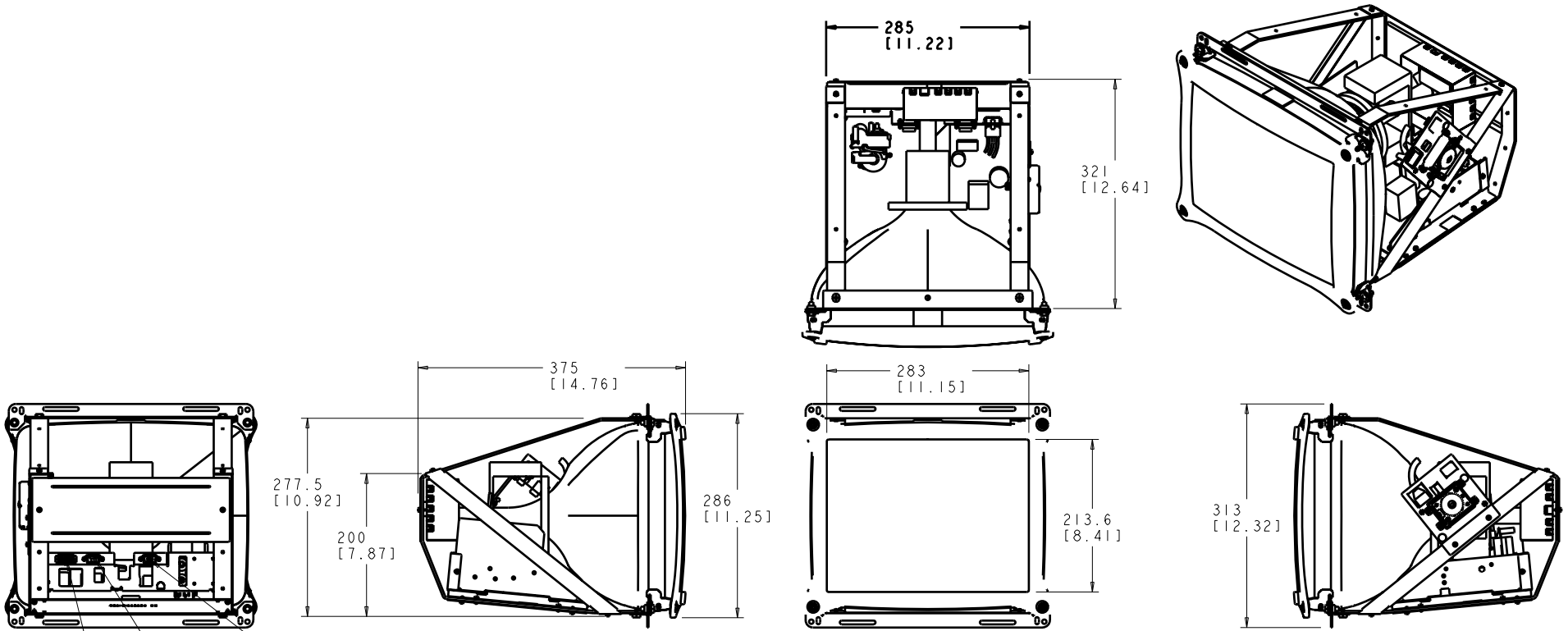

VIDEO CABLE VGA

TOUCH CABLE CONNECTOR SERIAL

POWER MATE & LOCK CONNECTOR * AMP 350766

- NOTES:**
- * USE AMP 350767 MATING MATE & LOCK CONNECTOR,
 - BRACKETS KIT PN C51251-000 MUST BE ORDERED SEPARATELY (SEE SHT.2).

PART NUMBER	PIP DESCRIPTION
E493538	ET1587C-4CWA-1-G

NOTE:
3D CAD FILES AVAILABLE IN IGES AND STEP FORMATS.

DIMENSIONS ARE IN MILLIMETERS/INCHES



ET1587C-XXWA-1-G
iTOUCH OPEN FRAME MONITOR
WITH OPTIONAL BOTTOM BRACKETS

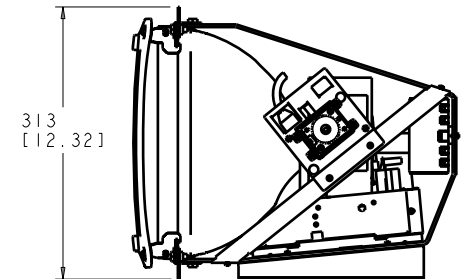
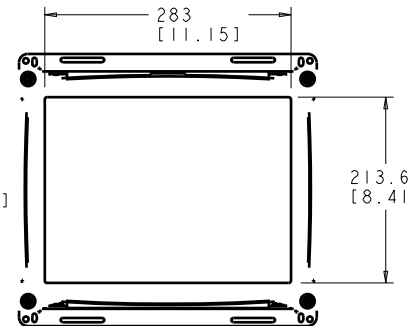
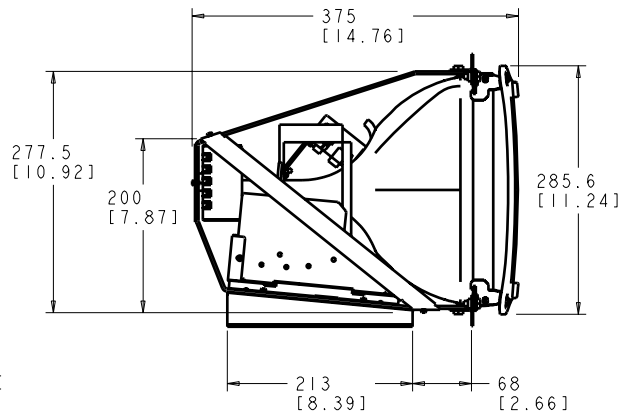
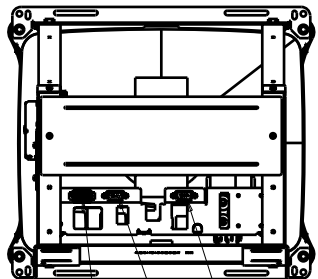
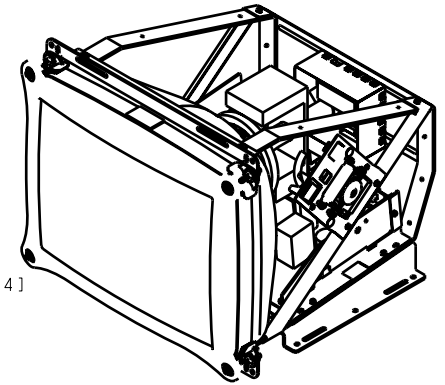
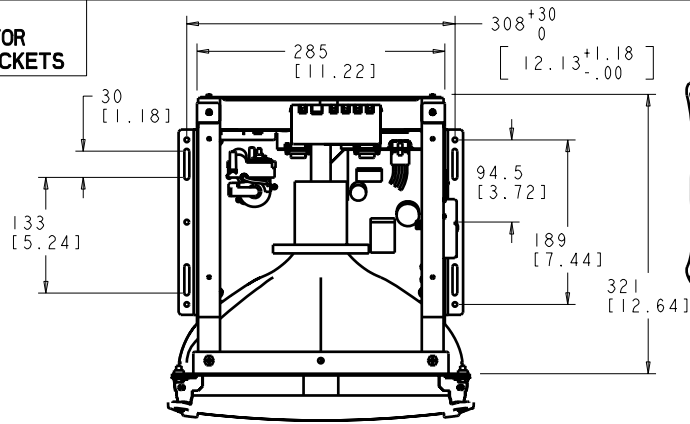

TOUCH CABLE
CONNECTOR
SERIAL

VIDEO
CABLE
VGA

POWER MATE&LOCK
CONNECTOR
*AMP 350766

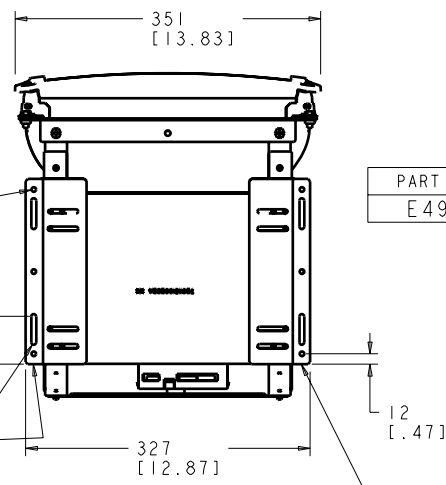

OPTIONAL
BRACKETS

PART NUMBER	DESCRIPTION	BRACKETS KIT
E493538	ET1587C-4CWA-1-G	C51251-000

DIMENSIONS ARE IN MILLIMETERS/INCHES

