

PROPRIETARY TO ELO TOUCHSYSTEMS, INC. AND SHALL NOT BE DISCLOSED OTHER THAN TO NECESSARY EMPLOYEES OR SUPPLIERS WITHOUT THE EXPRESS WRITTEN CONSENT OF ELO TOUCHSYSTEMS, INC.

**CARROLLTOUCH TOUCHSCREEN**

**SCN-CT-FLT15.0-OD2-00X-L**

REVISIONS					
REV	ZONE	BY	DESCRIPTION	DATE	APPROVED
A	--	HAG	RELEASED PER ECO 002430	09.27.02	

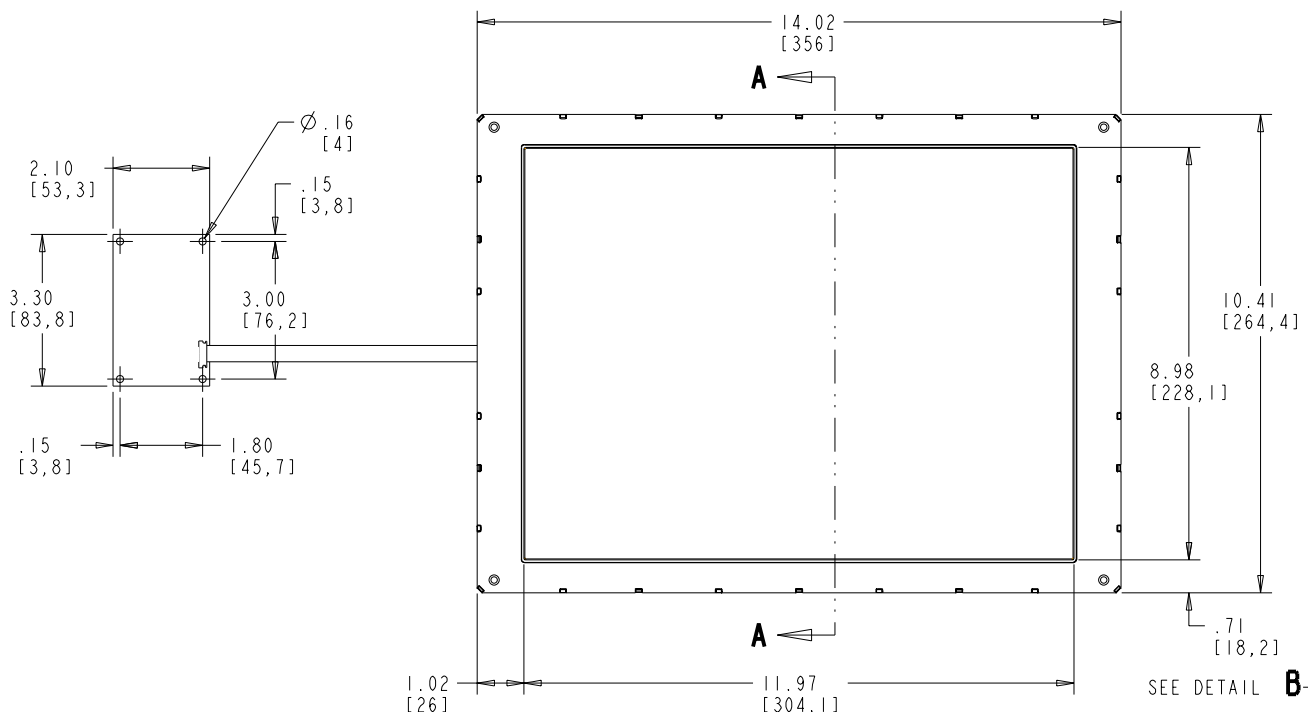

**FRONT VIEW**

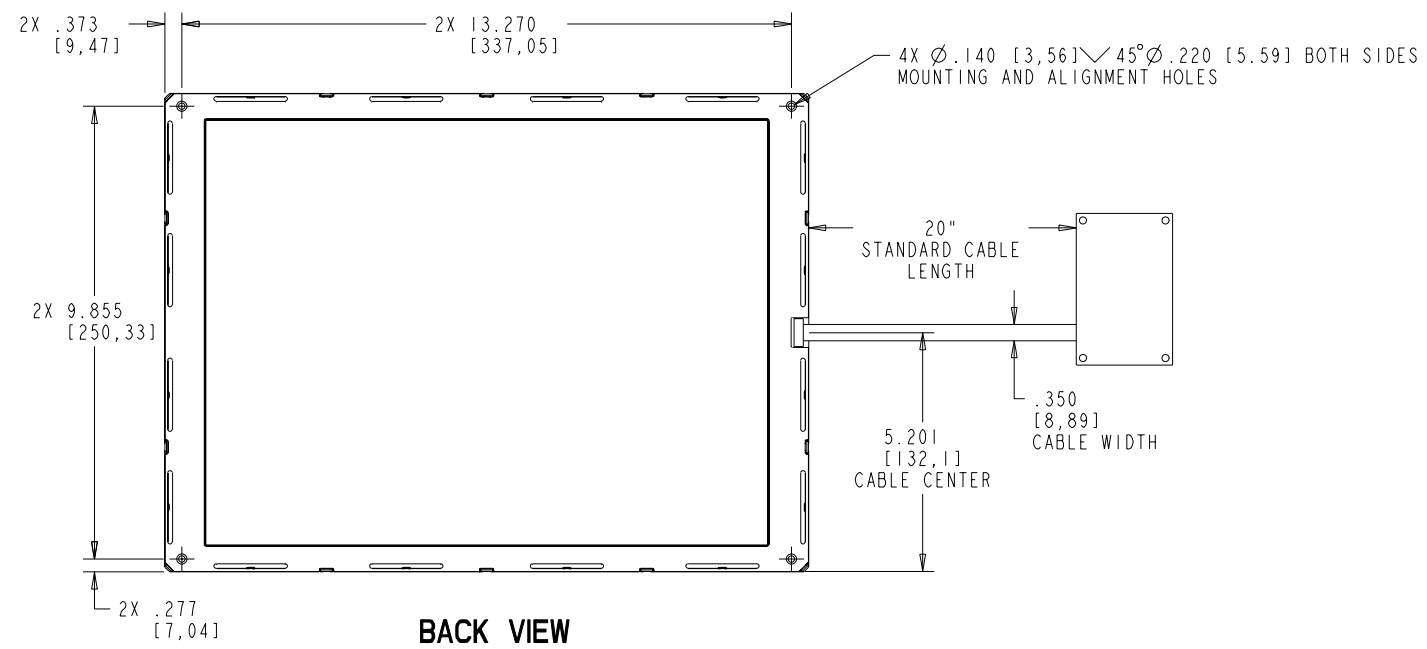

**BACK VIEW**

SECTION **A-A**

PIN OUT FOR P2 CONNECTOR ON CONTROLLER			
SIGNAL NAME	DB-9 PIN	P2 PIN	SOURCED BY
-DCD	1	1	ctrl
-DSR	6	2	ctrl
RXD	2	3	ctrl
-RTS	7	4	host
TXD	3	5	host
-CTS	8	6	ctrl
-DTR	4	7	host
RI	9	8	n/u
SG	5	9	com
n/u	n/c	10	n/u

PIN OUT FOR P4 CONNECTOR ON CONTROLLER		
SIGNAL NAME	P4 PIN	SIGNAL FUNCTION
+REGULATED PWR	1	+5 VOLTS DC +/-5%
PWR COM	2	SUPPLY VOLTAGE NEGATIVE
RESERVED	3	NO CONNECTION ALLOWED
PWR COM	4	SUPPLY VOLTAGE NEGATIVE
LED REMOTE	5	
n/c	6	KEY LOCATION
n/c	7	
FRAME GROUND	8	
-RESET	9	OPEN = NORMAL OPERATION SHORT TO PWR COM = HARDWARE RESET
RESERVED	10	NO CONNECTION ALLOWED

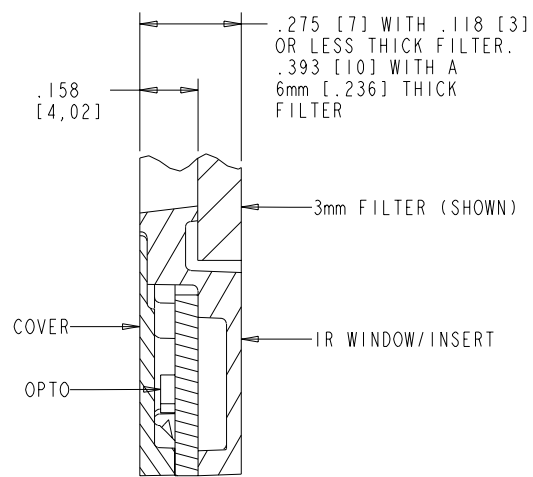

DETAIL **B**  
SCALE 4/1

**POTENTIAL DISPLAYS AND MEASUREMENTS**

MANUFACTURER	DISPLAY MODEL	ACTIVE AREA X	ACTIVE AREA Y	OUTSIDE X	OUTSIDE Y

PIP NUMBER	DESCRIPTION	FILTER TYPE
D87587-000	SCN-CT-FLT15.0-OD2-000-L	FILTERLESS
E71023-000	SCN-CT-FLT15.0-OD2-001-L	3mmTHK, ANTI-GLARE GLASS FLTR
568484-000	SCN-CT-FLT15.0-OD2-003-L	3mm THICK, ACRYLIC

ITEM NO.	QTY REQ'D	DRAWING OR PART NO.	DESCRIPTION	MATERIAL SPECIFICATION
PARTS LIST				
UNLESS OTHERWISE SPECIFIED ALL DIMENSIONS ARE IN MILLIMETERS		DRAWN A. GRICE	DATE 08.22.02	TITLE MTKG DWG, SCN-CT-FLT15.0-OD2-000-L SCN-CT-FLT15.0-OD2-001-L SCN-CT-FLT15.0-OD2-003-L
TOLERANCES ARE:		CHECK	DATE	
DECIMALS	ANGLES	DESIGN A. GRICE	DATE 08.22.02	
X ± 0.50 .X ± 0.25 .XX ± 0.13	±1/2° ±1/32	THIRD ANGLE PROJECTION		
DO NOT SCALE DRAWING				SIZE D SCALE 1/2 SHEET 1 OF 4 DWG. NO. <b>MS500308</b> REV <b>A</b>

SHEET 1 OF 4 REV A

# MOUNTING METHODS

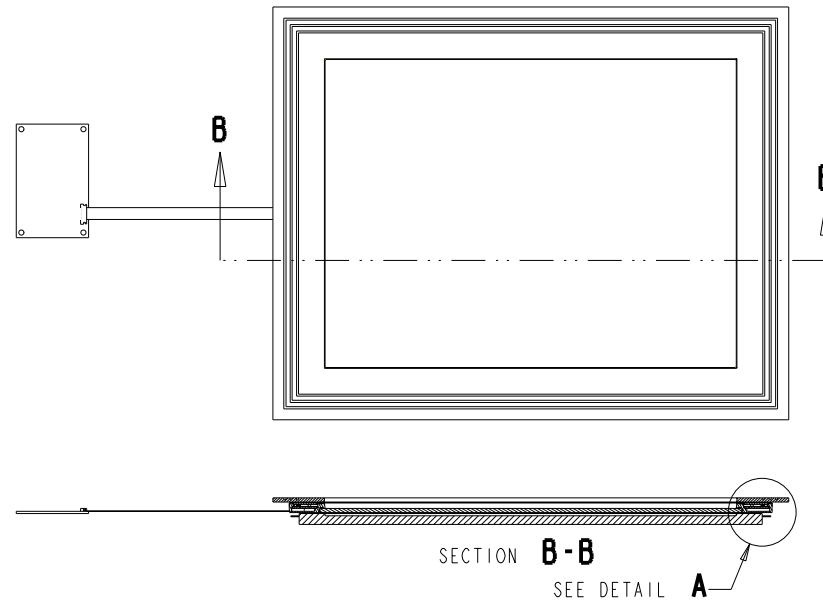
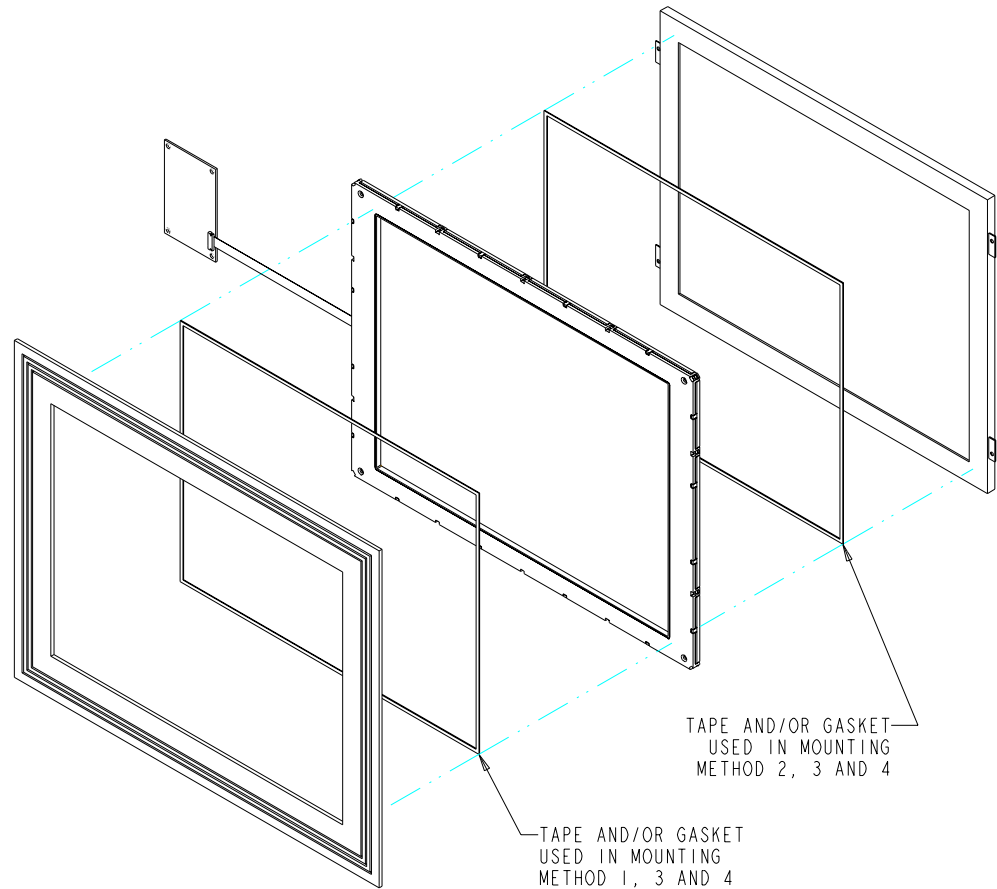

## RECOMMENDED TAPES/GASKETS

### BETWEEN CUSTOMER PANEL AND TOUCH SYSTEM (DOUBLE AND SINGLE SIDED ADHESIVE TAPE)

MOUNTING METHOD	MFG	MFG PART NUMBER	THICKNESS	COMPRESSED THICKNESS
1, 2 AND 3	3M	9500PL	.005 in (0.13 mm)	.005 in (0.13 mm)
	3M	4920	.015 in (0.4 mm)	.015 in (0.4 mm)
	EASTERN	2032AB	.032 in (0.8 mm)	.025 in (0.64 mm)
4	ROGERS CORP	4701-30	.09 in (2.29 mm)	.03 in (0.76 mm)

### BETWEEN DISPLAY AND TOUCH SYSTEM (SINGLE SIDED ADHESIVE TAPE ONLY)

MOUNTING METHOD	MFG	MFG PART NUMBER	THICKNESS	COMPRESSED THICKNESS
2, 3 AND 4	ROGERS CORP	4701-30	.09 in (2.29 mm)	.03 in (0.76 mm)

**NOTE:** WHENEVER APPLICABLE THE GASKET SHOULD BE MOUNTED TO THE TOUCH SYSTEM, FRO EASE OF INSTALLATION.

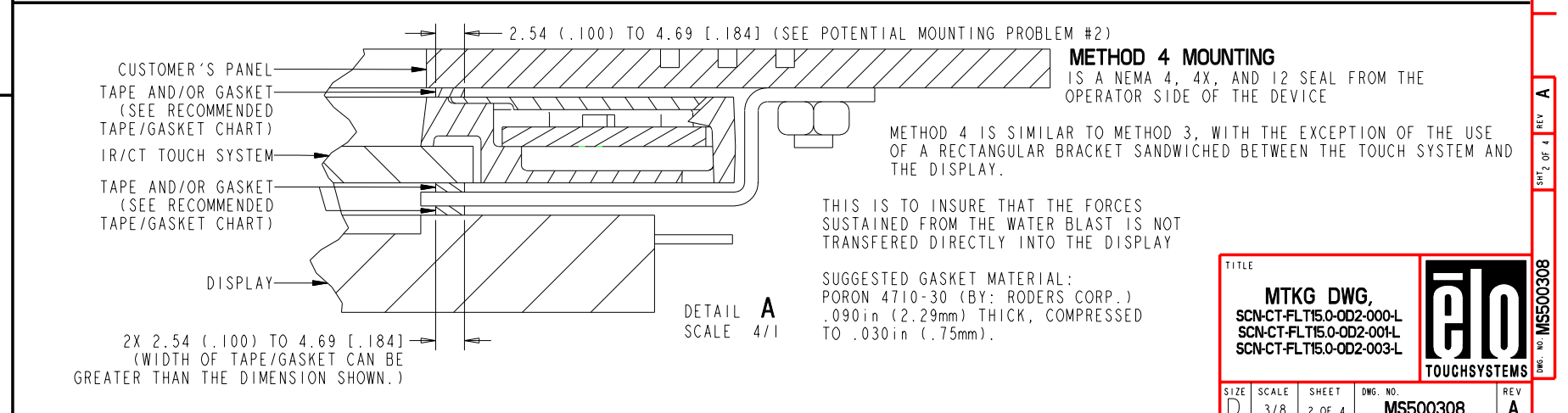
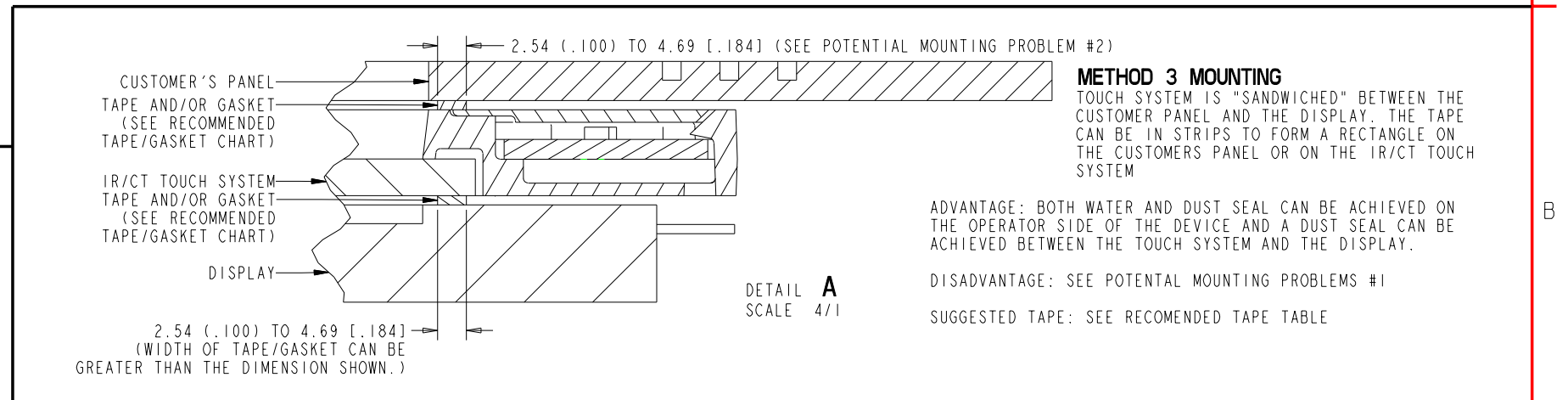
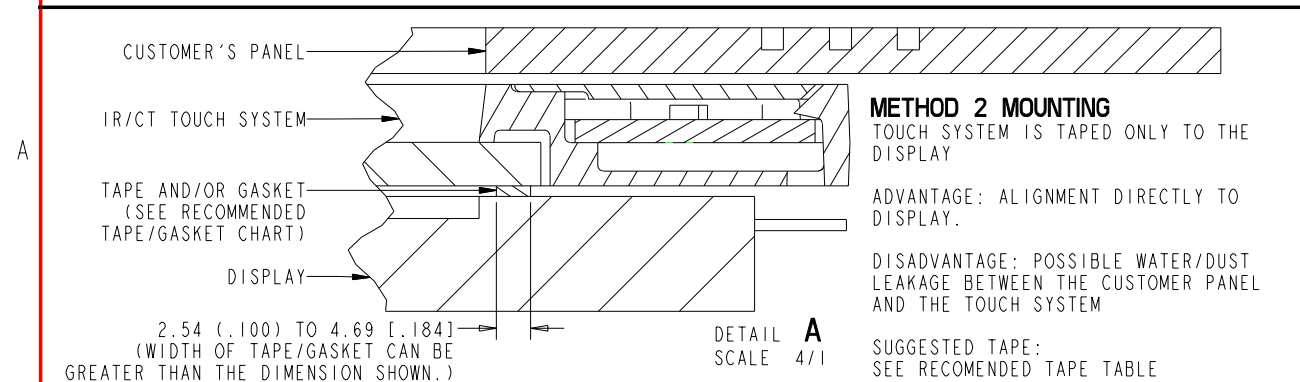
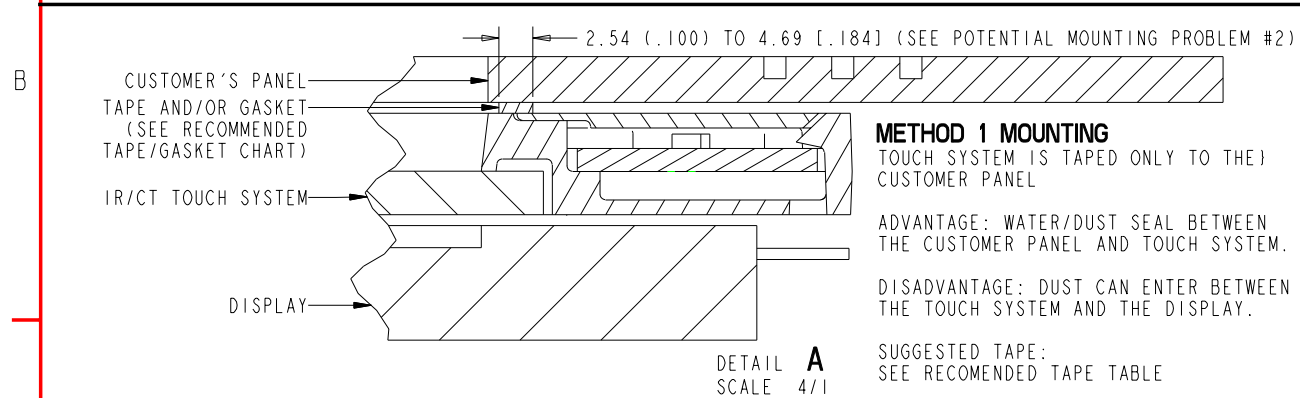

TITLE

MTKG DWG,  
SCN-CT-FLT15.0-OD2-000-L  
SCN-CT-FLT15.0-OD2-001-L  
SCN-CT-FLT15.0-OD2-003-L

SIZE D SCALE 3/8 SHEET 2 OF 4 DWG. NO. MS500308 REV A

# POTENTIAL MOUNTING PROBLEMS

POTENTIAL  
MOUNTING PROBLEM  
#1

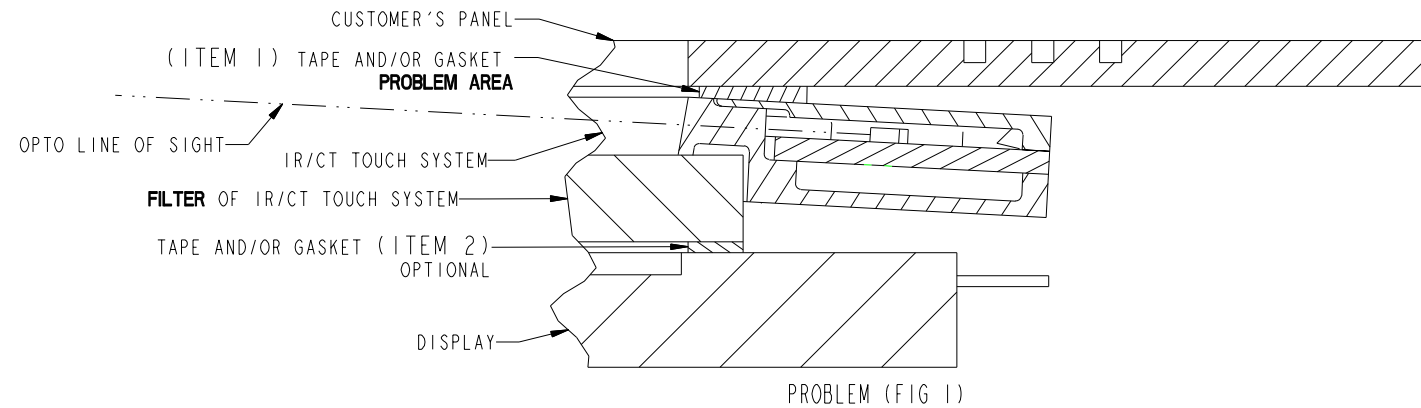

## GASKET (ITEM 1) TOO WIDE

**PROBLEM (FIG 1): WHEN THE FILTER IS GREATER THAN 3mm IN THICKNESS A SPACE IS CREATED BETWEEN THE PLASTIC PART OF THE TOUCH SYSTEM AND THE DISPLAY.** THUS, THE PROPER OPTO ALIGNMENT IS NOT ACHIEVED DUE TO EXTRA WIDTH OF TAPE/GASKET MOUNTED TO THE CUSTOMER PANEL. SEE SOLUTIONS BELOW.

## SOLUTION (FIG 2)

SOLUTION (FIG 2): MAKE THE GASKET (ITEM 1) SO THAT THE INSIDE OPENING DOES NOT PROTRUDE PAST THE EDGE OF THE TOUCH SYSTEM (EDGE 1) WHEN COMPRESSED AND THE OUTER OPENING LINES UP WITH THE OUTER EDGES OF THE FILTER (EDGE 2).

RECOMMENDED SPACER INSTALLATION WITH THE SOLUTION  
SEE TABLE FOR SPACER LENGTH.

## OVER CORRECTION (FIG 3)

SPACER INSTALLATION MAY CAUSE SLIGHT OVER CORRECTION OF OPTO LINE OF SIGHT (FIG 3). CORRECTION SHOULD BE LESS THAN 1mm.

## GASKET INTERFERENCE INTO OPTO LINE OF SIGHT (FIG 4)

**PROBLEMS:** (AS SEEN IN FIG 4)  
1) WHEN THE GASKET IS COMPRESSED IT MAY BLEED OVER INTO THE LINE OF SIGHT OF THE OPTO'S, CAUSING SIGNAL OBSTRUCTION.  
2) WHEN THE GASKET IS COMPRESSED IT MAYBE CUT, BY EDGE 1 OF THE TOUCH SYSTEM TEARING THE GASKET AND CAUSING WATER LEAKAGE.

**SOLUTION:** SET THE GASKET AWAY FROM EDGE 1 ABOUT .5mm TO 1mm (AS SEEN IN FIG 3) TO PROVIDE OPTIMUM GASKET EXPANSION DURING COMPRESSION WITHOUT BLEEDING OVER EDGE 1 INTO THE OPTO'S LINE OF SIGHT OR CUT GASKET OFF SO OPTO LINE OF SIGHT IS NOT OBSTRUCTED.

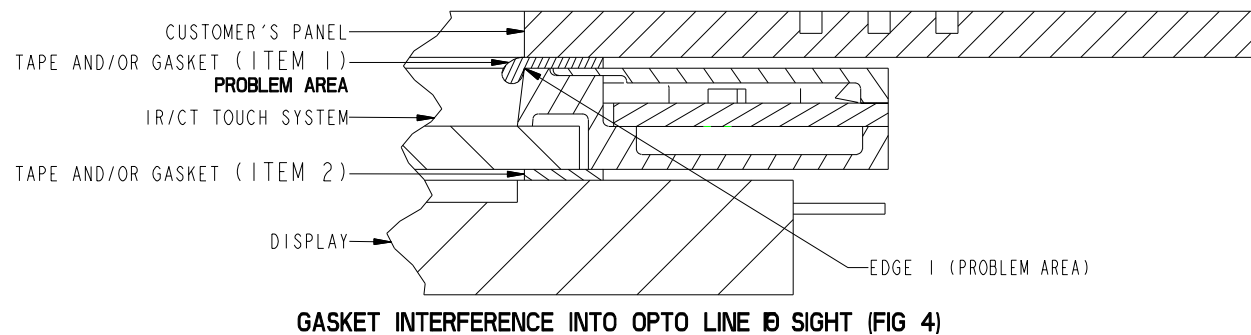
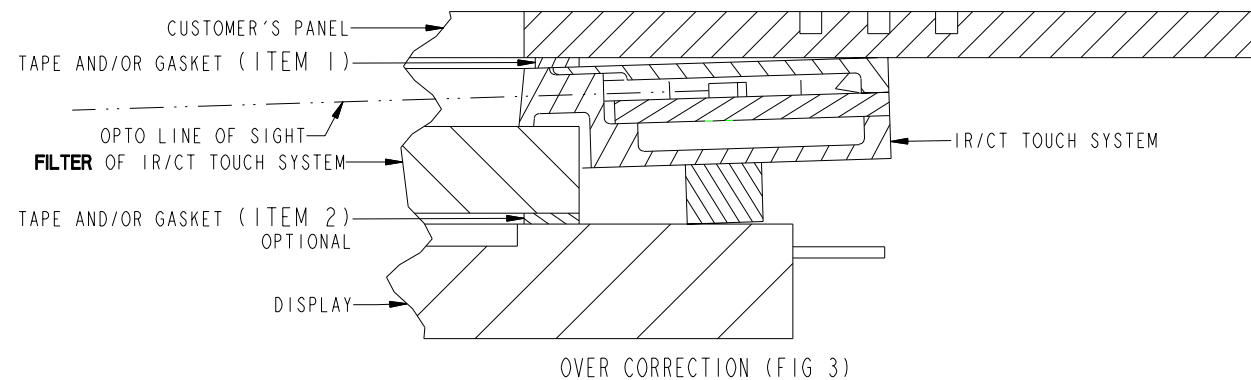
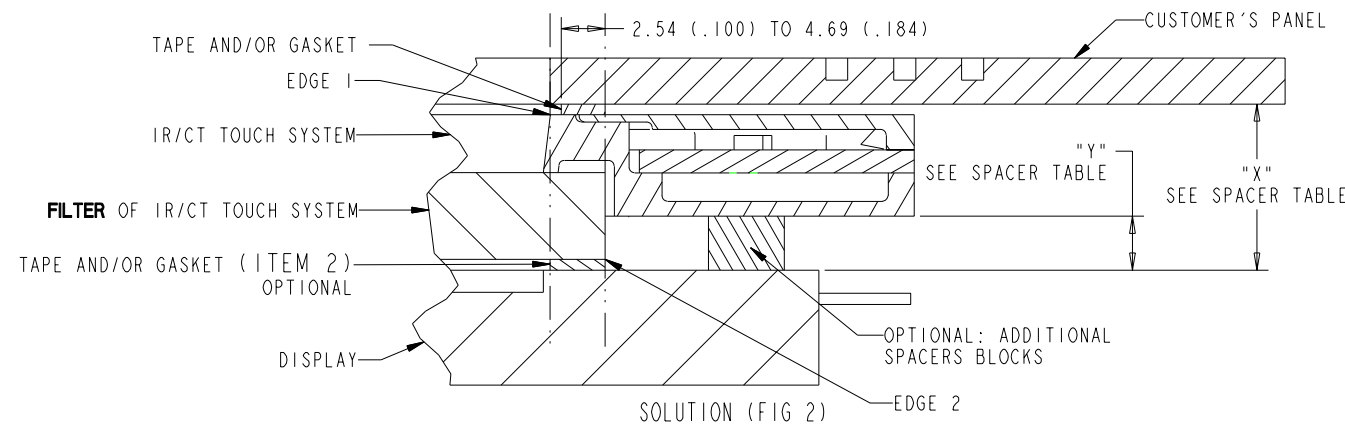

SPACER  
TABLE  
FOR FIG 2

DISTANCE "X"	SPACER LENGTH "Y"
7mm	3mm
8mm	4mm
9mm	5mm

\* PROVIDES .5mm OVER CORRECTION WHICH SLIGHTLY ENHANCES OPTICAL SIGNAL

POTENTIAL  
MOUNTING PROBLEM  
#2

TITLE		MTKG DWG, SCN-CT-FLT15.0-OD2-000-L SCN-CT-FLT15.0-OD2-001-L SCN-CT-FLT15.0-OD2-003-L		
SIZE	SCALE	SHEET	DWG. NO.	
D	1/2	3 OF 4	MS500308	A

PROPRIETARY TO ELO TOUCHSYSTEMS, INC. AND SHALL NOT BE DISCLOSED OTHER THAN TO NECESSARY EMPLOYEES OR SUPPLIERS WITHOUT THE EXPRESS WRITTEN CONSENT OF ELO TOUCHSYSTEMS, INC.

**CARROLL TOUCH TOUCHSCREEN**

**SCN-CT-FLT15.0-OD2-00X-L**

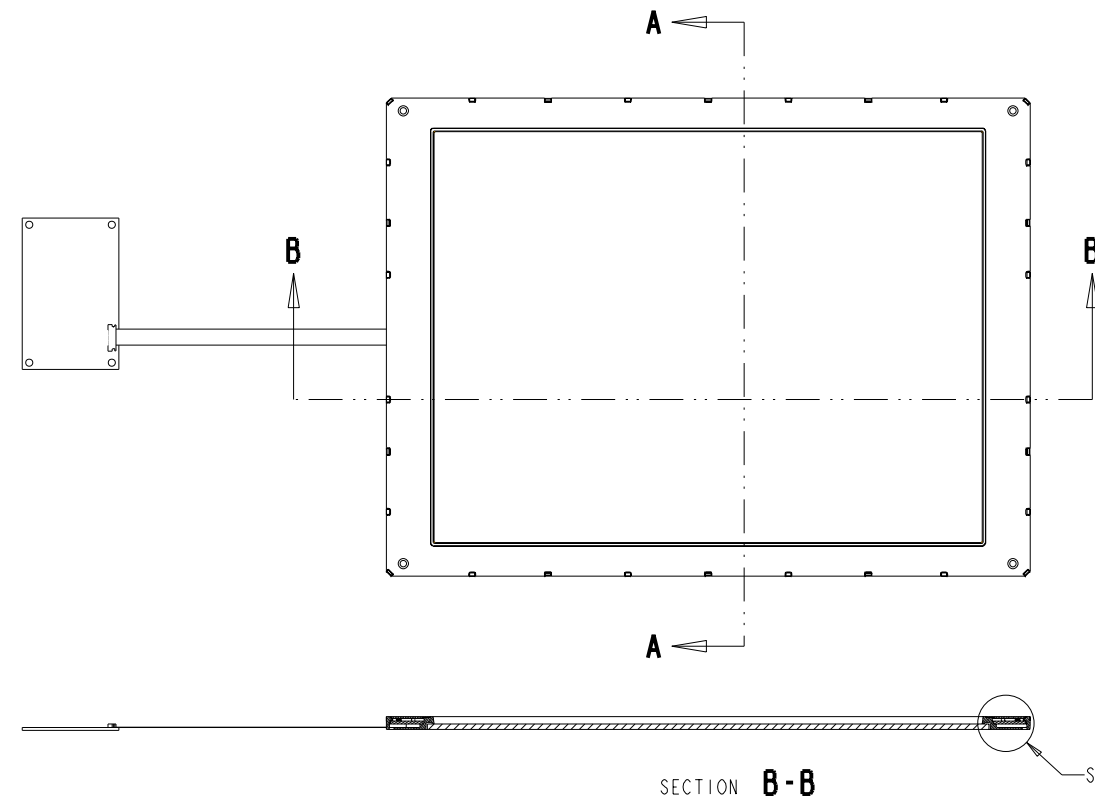

**ADHERING A FILTER TO A NO-FILTER CT TOUCH SYSTEM**

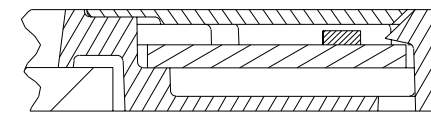

DETAIL **D**  
SCALE 4/1

SECTION **A-A**

SECTION **B-B**

SEE DETAIL **D**

**STEP 1**

APPLY ADHESIVE AND FILTER IN ACCORDANCE TO CT SPECIFICATION 2000-0375. SEE FIGURE 1. FILTER SIZE FOR THE 17LP IS 9.24 [234,7] X 12.23 [310,6]

**STEP 2**

AFTER CURING REMOVE EXCESS ADHESIVE FROM ASSEMBLY IN ACCORDANCE TO SPECIFICATION CT 2000-0375. SEE FIGURE 2.

**STEP 3**

THE FINAL ASSEMBLY SHOULD LOOK LIKE FIGURE 4.

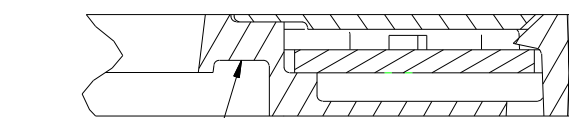

APPLY ADHESIVE AND FILTER

**FIGURE 1**

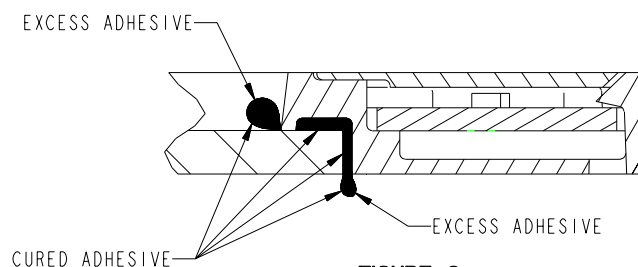

EXCESS ADHESIVE  
CURED ADHESIVE  
EXCESS ADHESIVE

**FIGURE 2**

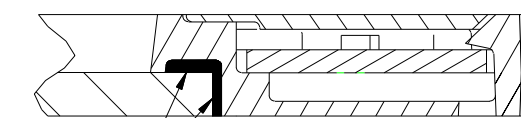

CURED ADHESIVE

**FIGURE 3**

**MOUNTING THE TOUCH SYSTEM USING ALIGNMENT HOLES AND NO COVER**

MAY BE ACHIEVED BY THE USE OF A SPACER TO OBTAIN THE STABILITY, RIGIDITY AND PROPER OPTO ALIGNMENT.

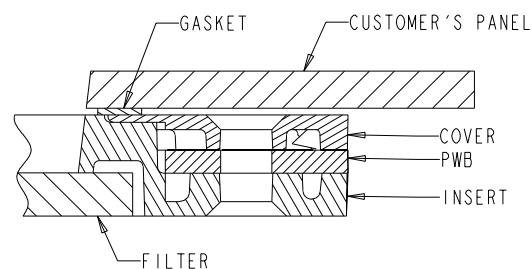

CROSS SECTION OF THE DESIGN CONFIGURATION WITH THE OPTO COVER INSTALLED.

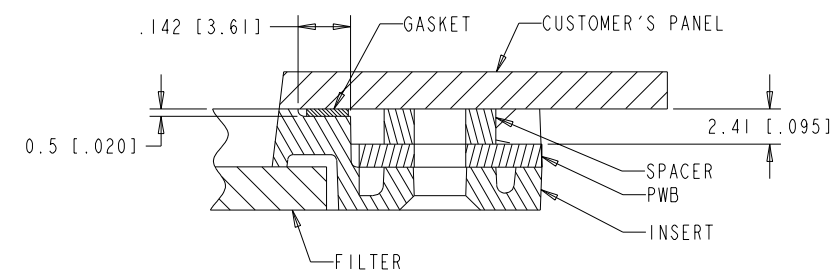

CROSS SECTION OF THE DESIGN CONFIGURATION WITH THE OPTO COVER REMOVED AND SPACER INSTALLED.

TITLE				
<p>MTKG DWG, SCN-CT-FLT15.0-OD2-000-L SCN-CT-FLT15.0-OD2-001-L SCN-CT-FLT15.0-OD2-003-L</p>				
SIZE	SCALE	SHEET	DWG. NO.	REV
D	1/2	4 OF 4	MS500308	A

ST 1 OF 4 REV A

DWG. NO. MS500308